



Franklin Electric

SUBMERSIBLE DRAINAGE PUMPS

FDR, FDP SERIES



INDEX

FDR SERIES - SUBMERSIBLE PUMPS FOR RESIDENTIAL DRAINAGE 50 HZ

Pump identification code..... 4

40FDR Series 50 HZ 5

Features & benefits 5
 General features 6
 Dimensional drawings..... 7
 Technical data 8
 Hydraulic performance at 50 Hz..... 8
 Performance curves at 50 Hz..... 9
 Installation..... 10

50FDR Series 50 HZ 11

Features & benefits 11
 General features 12
 Dimensional drawings..... 13
 Technical data 14
 Hydraulic performance at 50 Hz..... 14
 Performance curves at 50 Hz..... 15
 Installation..... 16

FDP SERIES - SUBMERSIBLE PUMPS FOR PROFESSIONAL DRAINAGE 50 HZ

Pump identification code..... 18

40-50FDP Series 50 HZ 19

Features & benefits 19
 General features 20
 Dimensional drawings..... 21
 Technical data 22
 Hydraulic performance at 50 Hz..... 22
 Performance curves at 50 Hz..... 23

40FDP-HH Series 50 HZ 24

Features & benefits 24
 General features 25
 Dimensional drawings..... 26
 Technical data 27
 Hydraulic performance at 50 Hz..... 27
 Performance curves at 50 Hz..... 28

70/80FDP Series 50 HZ 29

Features & benefits 29
 General features 30
 Dimensional drawings..... 31
 Technical data 32
 Hydraulic performance at 50 Hz..... 32
 Performance curves at 50 Hz..... 33

100FDP Series 50 HZ 34

Features & benefits 34
 General features 35
 Dimensional drawings..... 36
 Technical data 37
 Hydraulic performance at 50 Hz..... 37
 Performance curves at 50 Hz..... 38

NOTE: Franklin Electric reserves the right to amend specification without prior notice.

For the most up-to-date product information, visit franklinwater.eu.

100/150 FDP-LH/HH Series 50 HZ	39
Features & benefits	39
General features	40
Dimensional drawings	41
Technical data	42
Hydraulic performance at 50 Hz	42
Performance curves at 50 Hz	43
150FDP Series 50 HZ	44
Features & benefits	44
General features	45
Dimensional drawings	46
Technical data	47
Hydraulic performance at 50 Hz	47
Performance curves at 50 Hz	48

NOTE: Franklin Electric reserves the right to amend specification without prior notice.

For the most up-to-date product information, visit franklinwater.eu.



FDR Series - Submersible pumps for residential drainage 50 Hz



FDR SERIES - SUBMERSIBLE PUMPS FOR RESIDENTIAL DRAINAGE 50 HZ

PUMP IDENTIFICATION CODE

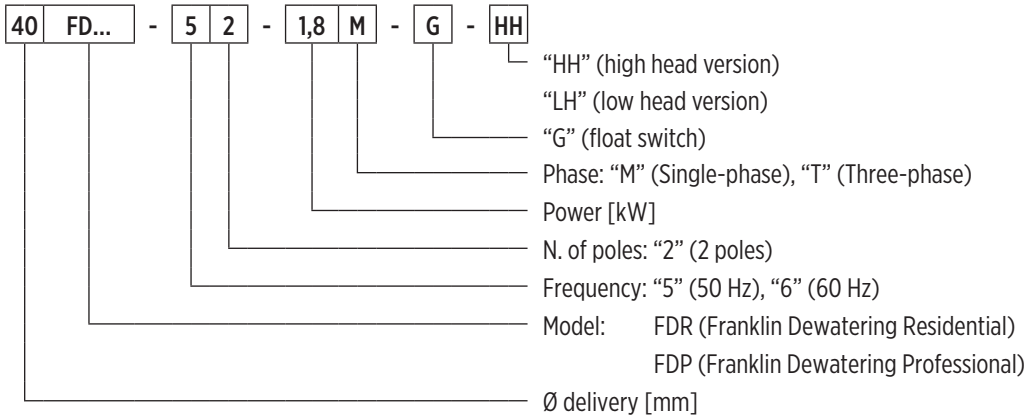

00140089 04/2023

40FDR SERIES 50 HZ

FEATURES & BENEFITS

APPLICATIONS



Drainage and dewatering
Draining rooms, tank
drainage



Rainwater Recovery



Extraction of water
from ponds, streams or
pits and for rainwater
collection



MARKETS



SUBMERSIBLE PUMPS FOR CLEAR AND TURBID WATER DRAINAGE

Submersible electric pumps in cast iron and stainless steel, suitable for draining clear and turbid waters. They can be used as ready-to-use portable pumps both for construction site use, basement wells, and for fixed installations with control panel.

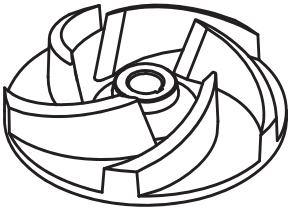

0030305 04/2023

OPEN IMPELLER

GENERAL FEATURES

		Materials/Constr.design
Open impeller		Cast iron EN GJL200
External casing		Stainless steel AISI304
Pump body		Cast iron EN GJL200
Cover		Cast iron EN GJL200
Filter		Aluminium alloy
Mechanical seal	motor side	Seal ring
	pump side	Graphite/Alumina
Motor shaft		Stainless steel AISI416
Power cable	Type	10 m H07RN-F type
	Single-phase	3G1mm ² with SCHUKO plug (CEE 7/VII)
	Three-phase	4G1mm ²
		Motor
Constr.design		asynchronous squirrel cage-type oil filled
Type		2 poles; 50 Hz
Insulation class		F
Protection degree		IP68
Voltage	Single-phase	230V ±6% built-in overheating protection, built in capacitor, float switch as optional
	Three-phase	230V ±10%, 400V ±10%
		Limits of use
Maximum liquid temperature		+ 40°C
pH of pumped liquid		6 - 10
Liquid density		1,0 kg/dm ³
Maximum immersion depth:		5 m
Min. immersion depth for continuous service		266 mm
Free passage		8 mm
Max. number of starting/hour		20
		Construction options

- 60 Hz version
- Different voltages
- Food-grade white oil
- Silicon carbide (SiC/SiC) mechanical seal

DIMENSIONAL DRAWINGS

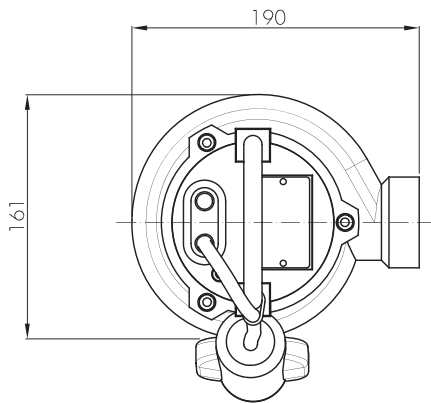
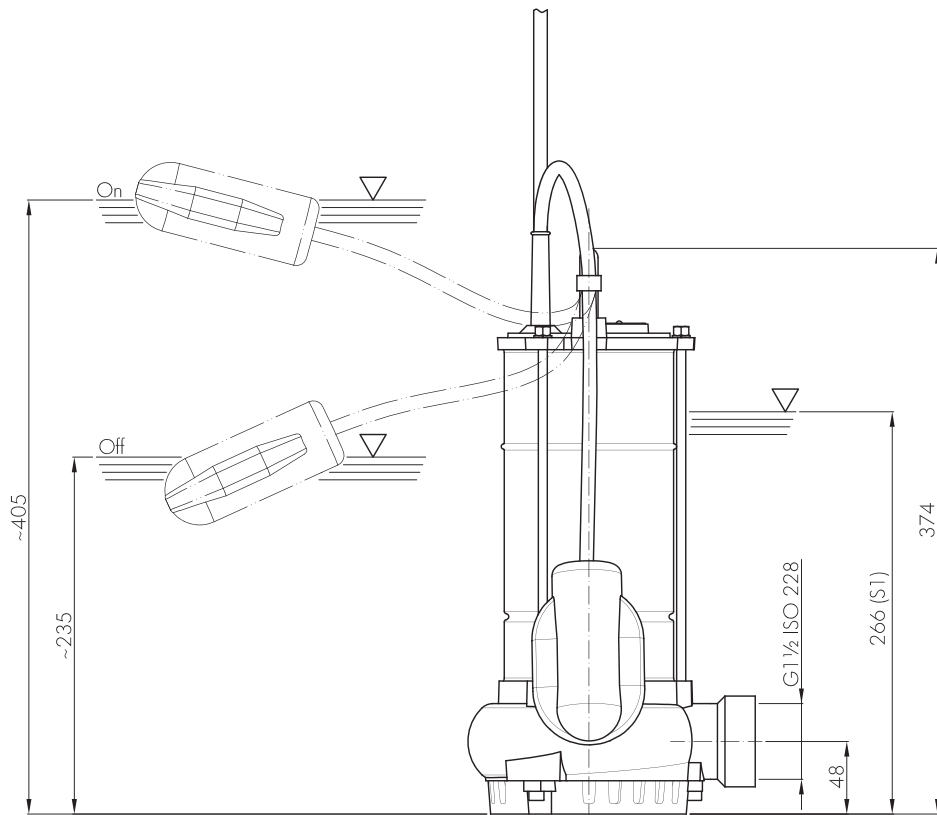

00130297 04/2023

Packaging		
Pump model	Dimensions [mm]	Weight [kg]
40FDR	225x180x450	11,5

Pallet			
Pump model	Dimensions [mm]	N° of pumps	Weight [kg]
40FDR-52-0,37	1200x800x800	32	400
40FDR-52-0,6	1200x800x800	32	400
40FDR-52-0,7	1200x800x800	32	500

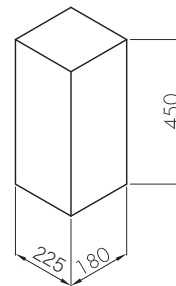
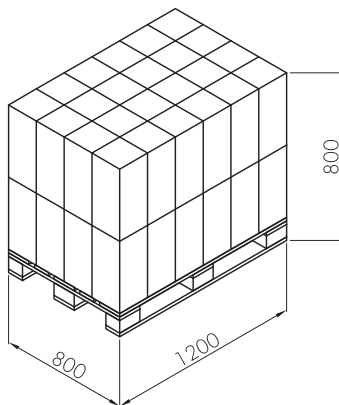

00130288 02/2023

TECHNICAL DATA

Pump model	Motor absorbed power P ₁	Rated power P ₂		Voltage	Rated current	Phase	Power cable		Float switch	Running capacitor	Delivery port	Weight [kg]
	[kW]	[kW]	[HP]	[V]	[A]		length [m]	Type		[μf]		
40FDR-52-0,37M	0,58	0,37	0,5	230	3	1~	10	3G1	-	8	G1½	11
40FDR-52-0,37M-G	0,58	0,37	0,5	230	3	1~	10	3G1	•	8	G1½	11
40FDR-52-0,6M	0,72	0,6	0,8	230	3,7	1~	10	3G1	-	10	G1½	11
40FDR-52-0,6M-G	0,72	0,6	0,8	230	3,7	1~	10	3G1	•	10	G1½	11
40FDR-52-0,7M	0,88	0,7	0,95	230	4,8	1~	10	3G1	-	14	G1½	14
40FDR-52-0,7T	0,88	0,7	0,95	400	1,8	3~	10	4G1	-	-	G1½	14
40FDR-52-0,7M-G	0,88	0,7	0,95	230	4,8	1~	10	3G1	•	14	G1½	14
40FDR-52-0,7T-G	0,88	0,7	0,95	400	1,8	3~	10	4G1	•	-	G1½	14

“-” = not available

“•” = available

HYDRAULIC PERFORMANCE AT 50 HZ

Pump model	Phase	Q = Delivery											
		l/sec 0	0,5	1	1,5	2	2,5	3	3,5	4	4,5	5	5,5
		m ³ /h 0	1,8	3,6	5,4	7,2	9	10,8	12,6	14,4	16,2	18	19,8
		US gpm 0	7,9	15,8	23,7	31,7	39,6	47,5	55,5	63,4	71,3	79,2	87,2
		H = Total meters head of water column [m]											
40FDR-52-0,37	1~	8	7,6	7,1	6,5	5,6	4,5	4	3	2			
40FDR-52-0,6	1~	8,9	8,2	8	7,1	6,8	6	5,4	4,5	3,8	2,8	2	
40FDR-52-0,7	1~	11	10,8	10,5	9,9	9,4	8,8	8,2	7,4	6,5	5,4	4,1	2,4
40FDR-52-0,7	3~	11	10,8	10,5	9,9	9,4	8,8	8,2	7,4	6,5	5,4	4,1	2,4

PERFORMANCE CURVES AT 50 HZ

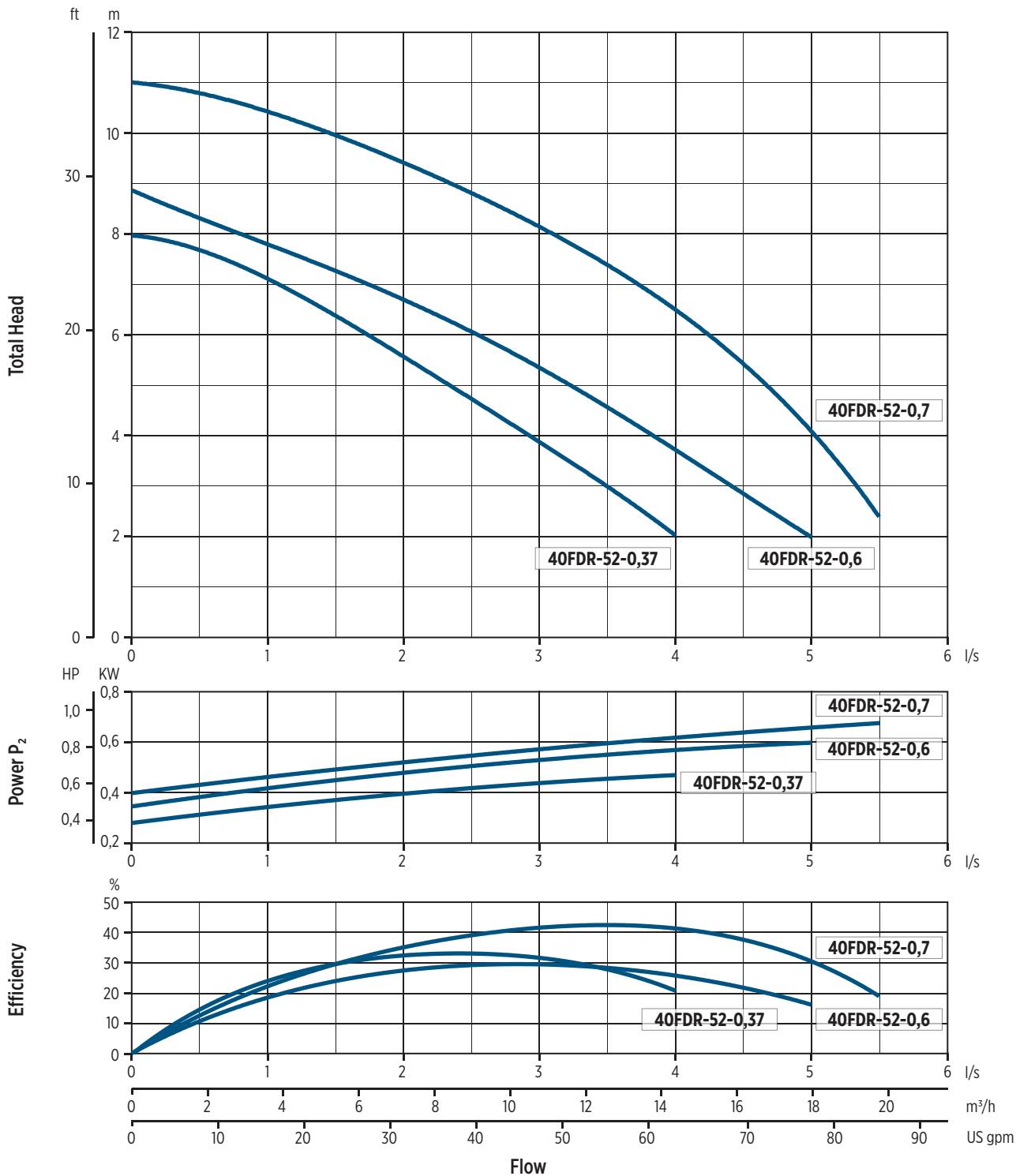

0020107_04/2023

INSTALLATION

INSTALLATION INSTRUCTIONS

TRANSPORTABLE INSTALLATION

Transportable as emergency pump with connection to the hose and for free installation in the well.

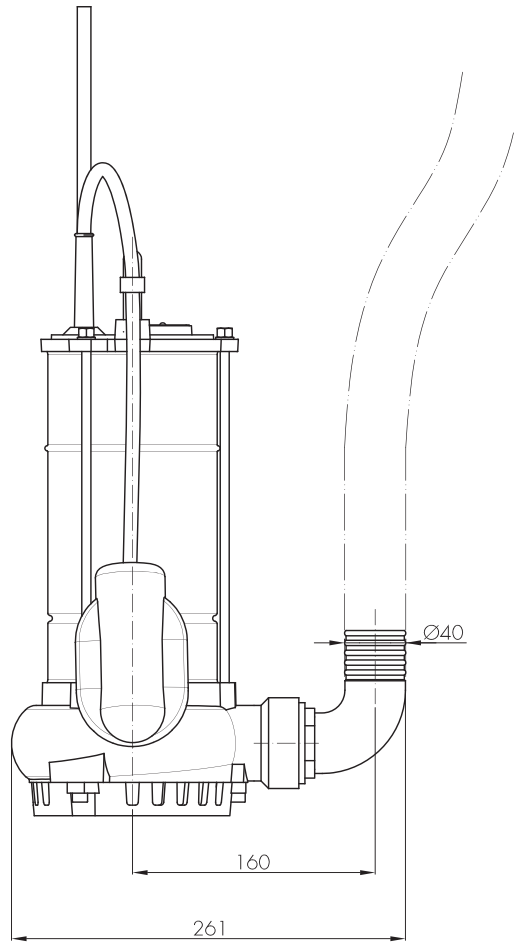

00130297 04/2023

50FDR SERIES 50 HZ

FEATURES & BENEFITS

APPLICATIONS



Drainage and dewatering
Draining rooms, tank
drainage



Rainwater Recovery



Extraction of water
from ponds, streams or
pits and for rainwater
collection



MARKETS



SUBMERSIBLE PUMPS FOR CLEAR AND TURBID WATER DRAINAGE

Submersible electric pumps in cast iron and stainless steel, suitable for draining clear and turbid waters. They can be used as ready-to-use portable pumps both for construction site use, basement wells, and for fixed installations with control panel.

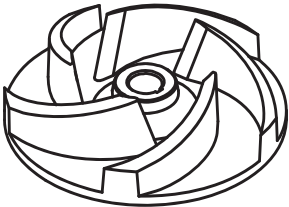

01030505-04/2023

OPEN IMPELLER

GENERAL FEATURES

		Materials/Constr.design
Open impeller		Cast iron EN GJL200
External casing		Stainless steel AISI304
Pump body		Cast iron EN GJL200
Cover		Cast iron EN GJL200
Filter		Stainless steel AISI304
Mechanical seal	motor side	Seal ring
	pump side	Silicon carbide (SiC/SiC)
Motor shaft		Stainless steel AISI420
Power cable	Type	10 m H07RN-F type
	Single-phase	3G1mm ² with SCHUKO plug (CEE 7/VII)
	Three-phase	4G1mm ²
		Motor
Constr.design		asynchronous squirrel cage-type in dry chamber
Type		2 poles; 50 Hz
Insulation class		F
Protection degree		IP68
Voltage	Single-phase	230V ±6% built-in overheating protection, built in capacitor, float switch as optional
	Three-phase	230V ±10%, 400V ±10%
		Limits of use
Maximum liquid temperature		+ 40°C
pH of pumped liquid		6 - 10
Liquid density		1,0 kg/dm ³
Maximum immersion depth:		5 m
Min. immersion depth for continuous service		329 mm
Free passage		6 mm
Max. number of starting/hour		20
		Construction options

- 60 Hz version
- Different voltages
- Food-grade white oil
- External capacitor with 4G1mm² cable

DIMENSIONAL DRAWINGS

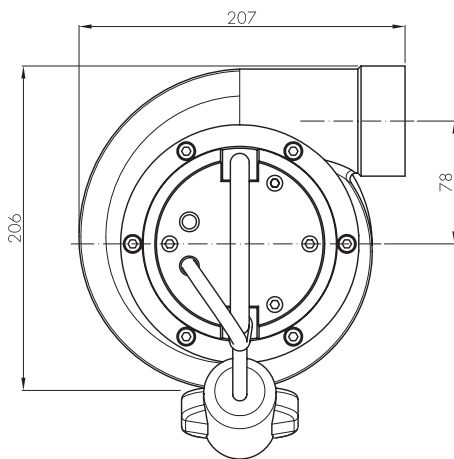
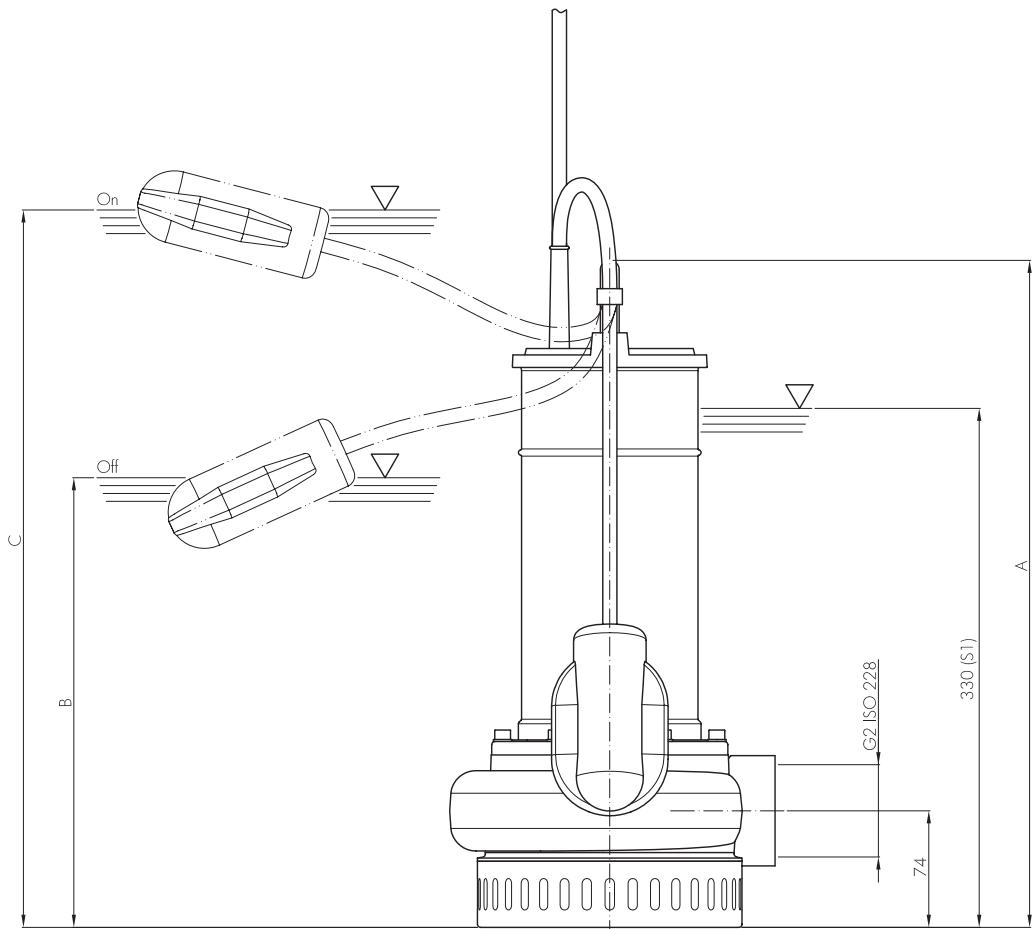

00050288 04/2023

Pump model	Dimensions [mm]		
	A	B	C
50FDR-52-0,9	424	260	460
50FDR-52-1,4	449	285	485

Pump model	Packaging	
	Dimensions [mm]	Weight [kg]
50FDR-52-0,9	255x205x560	18,7
50FDR-52-1,4	255x205x560	20,7

TECHNICAL DATA

Pump model	Motor absorbed power P ₁	Rated power P ₂		Voltage	Rated current	Phase	Power cable		Float switch	Running capacitor	Delivery port	Weight [kg]
	[kW]	[kW]	[HP]	[V]	[A]		length [m]	Type		[μf]		
50FDR-52-0,9M	1,2	0,9	1,2	230	5,6	1 ~	10	3G1	-	20	G2	18
50FDR-52-0,9M-G	1,2	0,9	1,2	230	5,6	1 ~	10	3G1	•	20	G2	18
50FDR-52-0,9T	1,2	0,9	1,2	400	2	3 ~	10	4G1	-	-	G2	18
50FDR-52-0,9T-G	1,2	0,9	1,2	400	2	3 ~	10	4G1	•	-	G2	18
50FDR-52-1,4M	1,8	1,4	1,9	230	8	1 ~	10	3G1	-	25	G2	20
50FDR-52-1,4M-G	1,8	1,4	1,9	230	8	1 ~	10	3G1	•	25	G2	20
50FDR-52-1,4T	1,8	1,4	1,9	400	3,8	3 ~	10	4G1	-	-	G2	20

"-" = not available

• = available

HYDRAULIC PERFORMANCE AT 50 HZ

Pump model	Phase	Q = Delivery															
		l/sec 0	1	1,5	2	2,5	3	3,5	4	4,5	5	6	7	8	9	10	
		m ³ /h 0	3,6	5,4	7,2	9	10,8	12,6	14,4	16,2	18	21,6	25,2	28,8	32,4	36	
		US gpm 0	15,8	23,7	31,7	39,6	47,5	55,5	63,4	71,3	79,2	92,1	110,9	126,8	142,6	158,5	
		H = Total meters head of water column [m]															
50FDR-52-0,9	1 ~	14,8	14	13,5	13,2	12,5	12	11,1	10,6	9,7	8,7	7,2	4,7	2,5			
	3 ~	14,8	14	13,5	13,2	12,5	12	11,1	10,6	9,7	8,7	7,2	4,7	2,5			
50FDR-52-1,4	1 ~	18	17,7	17,5	17,2	16,6	16,4	15,9	15,5	14,2	14	12,8	10,5	9	6,8	4,2	
	3 ~	18	17,7	17,5	17,2	16,6	16,4	15,9	15,5	14,2	14	12,8	10,5	9	6,8	4,2	

PERFORMANCE CURVES AT 50 HZ

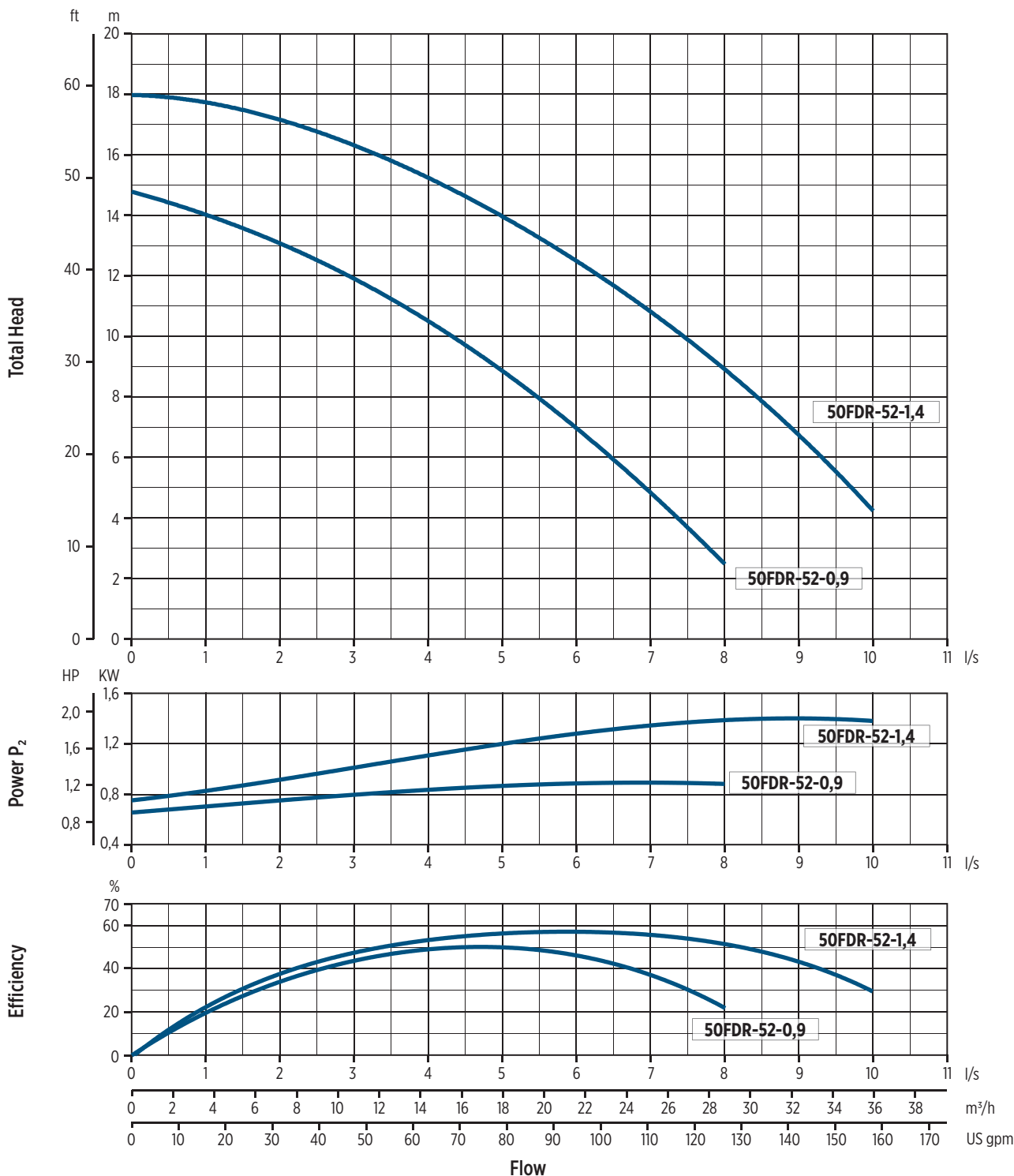

00202008.04/2023

INSTALLATION

INSTALLATION INSTRUCTIONS

TRANSPORTABLE INSTALLATION

Transportable as emergency pump with connection to the hose and for free installation in the well.

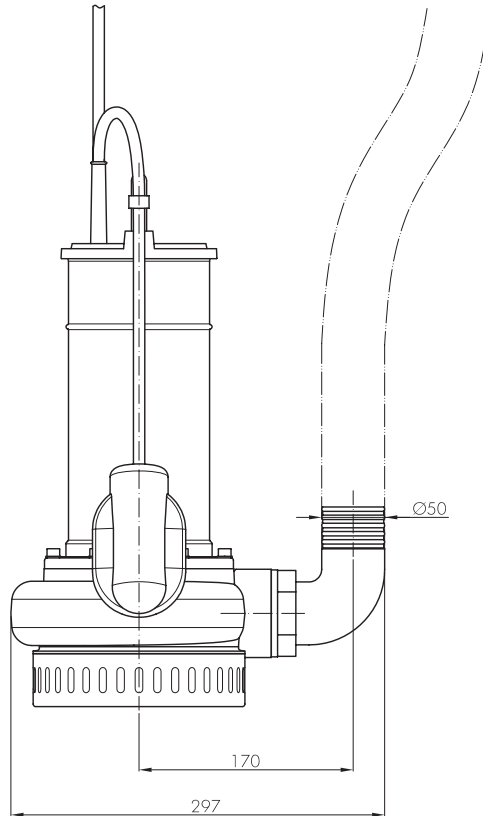

00150298 04/2023

FDP Series - Submersible pumps for professional drainage 50 Hz



FDP SERIES - SUBMERSIBLE PUMPS FOR PROFESSIONAL DRAINAGE 50 HZ

PUMP IDENTIFICATION CODE

40 | FD... | - | 5 | 2 | - | 1,8 | M | - | G | - | HH

- “HH” (high head version)
- “LH” (low head version)
- “G” (float switch)
- Phase: “M” (Single-phase), “T” (Three-phase)
- Power [kW]
- N. of poles: “2” (2 poles)
- Frequency: “5” (50 Hz), “6” (60 Hz)
- Model: FDR (Franklin Dewatering Residential)
FDP (Franklin Dewatering Professional)
- Ø delivery [mm]

00140089 04/2023



40-50FDP SERIES 50 HZ

FEATURES & BENEFITS

APPLICATIONS



Drainage and dewatering



Rainwater Recovery



Construction site drainage and dewatering



Mining, Quarrying drainage and dewatering



MARKETS



SUBMERSIBLE PUMPS FOR CLEAR AND TURBID WATER DRAINAGE

Submersible electric pumps in cast iron and stainless steel, suitable for draining clear and turbid waters. They can be used as ready-to-use portable pumps both for construction site use, basement wells, and for fixed installations with control panel.

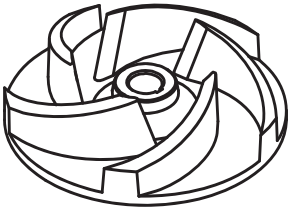

0032625 04/2023

OPEN IMPELLER

GENERAL FEATURES

		Materials/Constr.design
Open impeller		Cast iron EN GJL200
External casing		Aluminium alloy EN AW6060
Pump body		Aluminium alloy
Cover		Aluminium alloy
Filter		Aluminium alloy
Wear plate	40FDP-52-1,0M	Stainless steel AISI304
	50FDP-52-1,4M, 50FDP-52-1,8M	Aluminium alloy with rubber coating
Mechanical seal		Silicon carbide (SiC/SiC)
Motor shaft		Stainless steel AISI420
Power cable	Type	10 m H07RN-F type
	Single-phase 40FDP-52-1,0M	4G1,5mm ² , capacitor box and SCHUKO plug (CEE 7/VII)
	Single-phase 50FDP-52-1,4M, 50FDP-52-1,8M	4G2,5mm ² , capacitor box and SCHUKO plug (CEE 7/VII)
	Three-phase	4G1,5mm ²
		Motor
Constr.design		asynchronous squirrel cage-type oil filled
Type		2 poles; 50 Hz
Insulation class		F
Protection degree		IP68
Voltage	Single-phase	230V ±6% built-in overheating protection (up to 1,1 kW), float switch as optional
	Three-phase	230V ±10%, 400V ±10%
		Limits of use
Maximum liquid temperature		+ 40°C
pH of pumped liquid		5 - 8
Liquid density		1,0 Kg/dm ³
Maximum immersion depth:		5 m
Min. immersion depth for continuous service		see "Dimensional drawings"
Free passage		6 mm
Max. number of starting/hour		20
		Construction options

- 60 Hz version
- Different voltages
- Food-grade white oil

DIMENSIONAL DRAWINGS

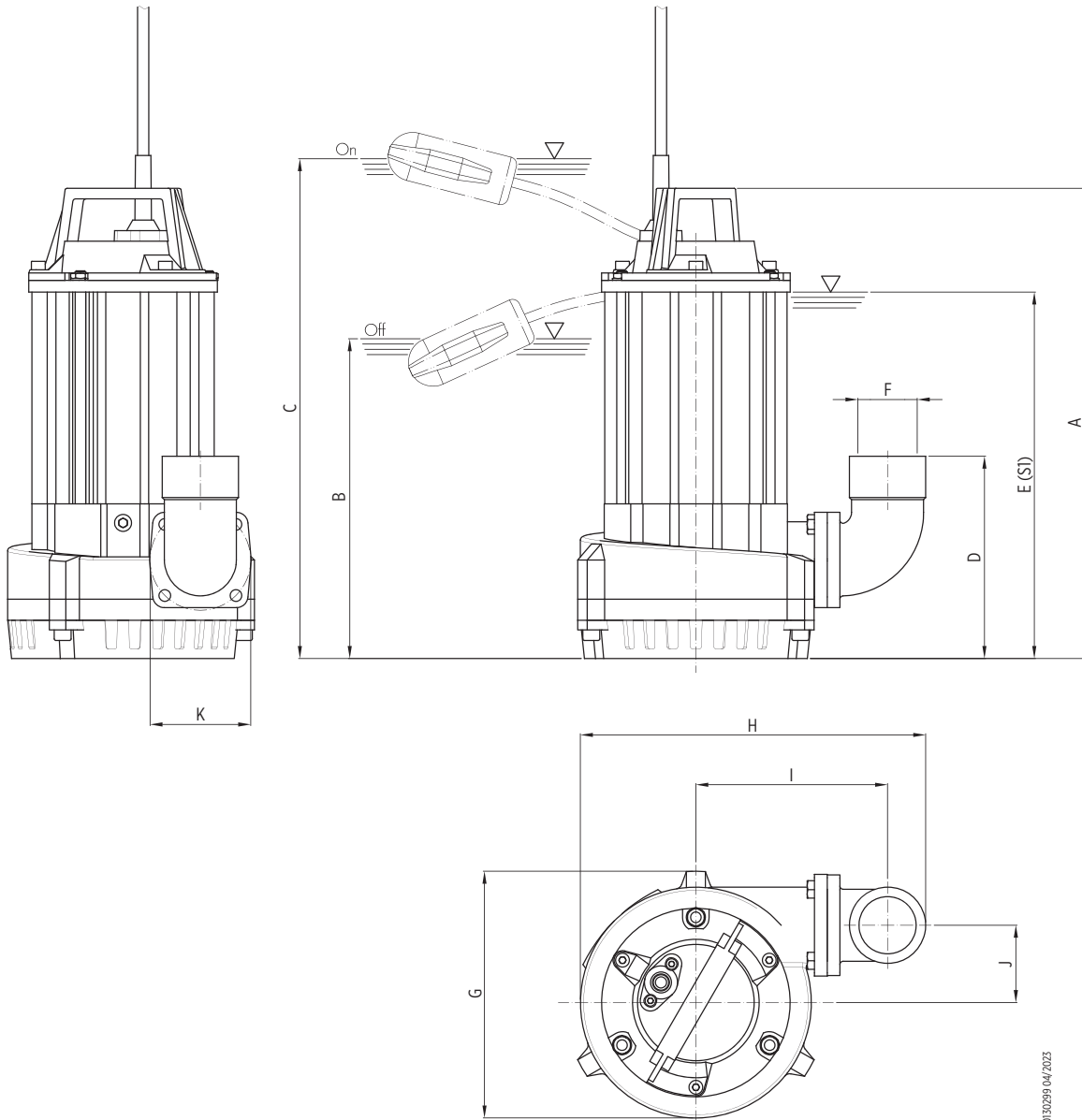

00130295_04/2023

Pump model	Dimensions [mm]										
	A	B	C	D	E	F	G	H	I	J	K
40FDP-52-1,0M	390	-	-	162	290	G1½	190	290	175	60	75
40FDP-52-1,0T	390	-	-	162	290	G1½	190	290	175	60	75
40FDP-52-1,0M-G	390	230	440	162	290	G1½	190	290	175	90	75
40FDP-52-1,0T-G	390	-	-	162	290	G1½	190	290	175	60	75
40FDP-52-1,1T	390	-	-	162	290	G1½	190	290	175	60	75
40FDP-52-1,1T-G	390	-	-	162	290	G1½	190	290	175	60	75
50FDP-52-1,4M	445	-	-	190	345	G2	233	326	180	73	95
50FDP-52-1,4M-G	485	240	530	190	345	G2	233	326	180	73	95
50FDP-52-1,8M	445	-	-	190	345	G2	233	326	180	73	95
50FDP-52-1,8T	445	-	-	190	345	G2	233	326	180	73	95
50FDP-52-1,8M-G	485	240	530	190	345	G2	233	326	180	73	95
50FDP-52-1,8T-G	485	240	530	190	345	G2	233	326	180	73	95
50FDP-52-2,2T	445	-	-	190	345	G2	233	326	180	73	95
50FDP-52-2,2T-G	485	240	530	190	345	G2	233	326	180	73	95

Packaging		
Pump model	Dimensions [mm]	Weight [kg]
40FDP-52-1,0M	255x205x560	20,7
40FDP-52-1,0T	255x205x560	20,7
40FDP-52-1,0M-G	290x245x585	21
40FDP-52-1,0T-G	255x205x560	20,7
40FDP-52-1,1T	255x205x560	20,7
40FDP-52-1,1T-G	255x205x560	22,7
50FDP-52-1,4M	300x260x585	24
50FDP-52-1,4M-G	300x260x585	26
50FDP-52-1,8M	300x260x585	28
50FDP-52-1,8T	300x260x585	26
50FDP-52-1,8M-G	300x260x585	30
50FDP-52-1,8T-G	300x260x585	28
50FDP-52-2,2T	300x260x585	27
50FDP-52-2,2T-G	300x260x585	29

TECHNICAL DATA

Pump model	Motor absorbed power P ₁	Rated power P ₂		Voltage	Rated current	Phase	Power cable		Float switch	Running capacitor	Delivery port	Weight [kg]
	[kW]	[kW]	[HP]	[V]	[A]		length [m]	Type		[μf]		
40FDP-52-1,0M	1,4	1	1,36	230	7,2	1 ~	10	4G1,5	-	25	G1½	20
40FDP-52-1,0T	1,4	1	1,36	400	2	3 ~	10	4G1,5	-	-	G1½	20
40FDP-52-1,0M-G	1,4	1	1,36	230	7,2	1 ~	10	4G1,5	•	25	G1½	20
40FDP-52-1,0T-G	1,4	1	1,36	400	2	3 ~	10	4G1,5	•	-	G1½	20
40FDP-52-1,1T	1,7	1,1	1,5	400	3	3 ~	10	4G1,5	-	-	G1½	20
40FDP-52-1,1T-G	1,7	1,1	1,5	400	3	3 ~	10	4G1,5	•	-	G1½	22
50FDP-52-1,4M	2,1	1,4	1,9	230	12	1 ~	10	4G2,5	-	25	G2	23
50FDP-52-1,4M-G	2,1	1,4	1,9	230	12	1 ~	10	4G2,5	•	25	G2	25
50FDP-52-1,8M	2,4	1,8	2,4	230	14	1 ~	10	4G2,5	-	30	G2	27
50FDP-52-1,8T	2,4	1,8	2,4	400	4,6	3 ~	10	4G1,5	-	-	G2	25
50FDP-52-1,8M-G	2,4	1,8	2,4	230	14	1 ~	10	4G2,5	•	30	G2	29
50FDP-52-1,8T-G	2,4	1,8	2,4	400	4,6	3 ~	10	4G1,5	•	-	G2	27
50FDP-52-2,2T	2,9	2,2	3	400	5	3 ~	10	4G1,5	-	-	G2	26
50FDP-52-2,2T-G	2,9	2,2	3	400	5	3 ~	10	4G1,5	•	-	G2	28

“-” = not available

• = available

HYDRAULIC PERFORMANCE AT 50 HZ

Pump model	Phase	Q = Delivery															
		l/sec 0	1	2	3	4	5	6	7	8	9	10	11	12	13	14	15
		m ³ /h 0	3,6	7,2	10,8	14,4	18	21,6	25,2	28,8	32,4	36	39,6	43,2	46,8	50,4	54
		US gpm 0	15,8	31,7	47,5	63,4	79,2	92,1	110,9	126,8	142,6	158,5	174,3	190,2	206	221,9	237,7
		H = Total meters head of water column [m]															
40FDP-52-1,0	1 ~	18	16,5	15	13,5	11	8	4,5	1								
	3 ~	18	16,5	15	13,5	11	8	4,5	1								
40FDP-52-1,1	3 ~	20	18,5	17	15,5	13,5	11	8,5	5								
50FDP-52-1,4	1 ~	14,3	14,1	13,7	13,1	12,5	11,8	11	9,8	8,5	7	6	4,5	2,8			
50FDP-52-1,8	1 ~	16,6	16,3	16,1	15,8	15,1	14,2	14	12,8	11,8	10,2	9	7	5,8	4	2	
	3 ~	16,6	16,3	16,1	15,8	15,1	14,2	14	12,8	11,8	10,2	9	7	5,8	4	2	
50FDP-52-2,2	3 ~	18,5	18,5	18,2	17,8	17,5	16,5	16	14,7	13,9	12	10,5	9,1	7,5	5,8	4	2

PERFORMANCE CURVES AT 50 HZ

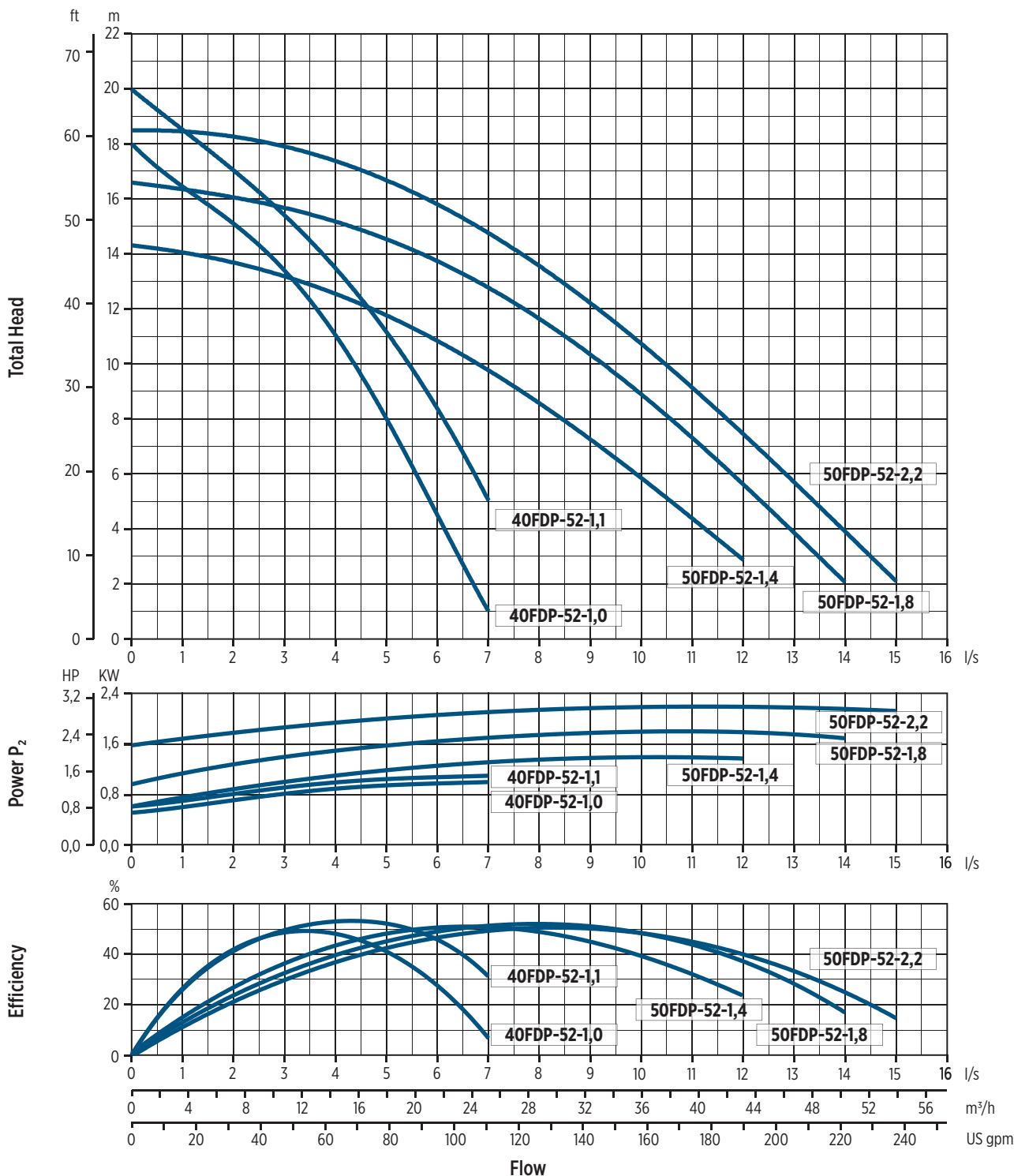

40FDP-HH SERIES 50 HZ

FEATURES & BENEFITS

APPLICATIONS



Drainage and dewatering



Rainwater Recovery



Construction site drainage and dewatering



Mining, Quarrying drainage and dewatering



MARKETS



HIGH HEAD VERSION SUBMERSIBLE PUMPS FOR CLEAR AND TURBID WATER DRAINAGE

Submersible electric pumps in cast iron and stainless steel, suitable for draining clear and turbid waters. They can be used as ready-to-use portable pumps both for construction site use, basement wells, and for fixed installations with control panel.

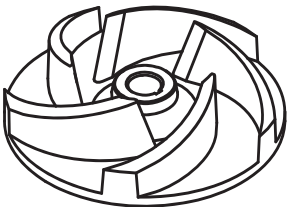

DOUBLE OPEN IMPELLER

0033056 04/2023

GENERAL FEATURES

		Materials/Constr.design
Double open impeller		Cast iron EN GJL200
External casing		Aluminium alloy EN AW6060
Pump body		Aluminium alloy
Cover		Aluminium alloy
Filter		Aluminium alloy
Wear plate		Stainless steel AISI304
Mechanical seal		Silicon carbide (SiC/SiC)
Motor shaft		Stainless steel AISI431
Power cable	Type	10 m H07RN-F type
	Single-phase	4G2,5mm ² , capacitor box and SCHUKO plug (CEE 7/VII)
	Three-phase	4G1,5mm ²
		Motor
Constr.design		asynchronous squirrel cage-type oil filled
Type		2 poles; 50 Hz
Insulation class		F
Protection degree		IP68
Voltage	Single-phase	230V ±6%, float switch as optional
	Three-phase	230V ±10%, 400V ±10%
		Limits of use
Maximum liquid temperature		+ 40°C
pH of pumped liquid		5 - 8
Liquid density		1,0 Kg/dm ³
Maximum immersion depth:		5 m
Min. immersion depth for continuous service		331 mm
Free passage		6 mm
Max. number of starting/hour		20
		Construction options

- 60 Hz version
- Different voltages
- Food-grade white oil

DIMENSIONAL DRAWINGS

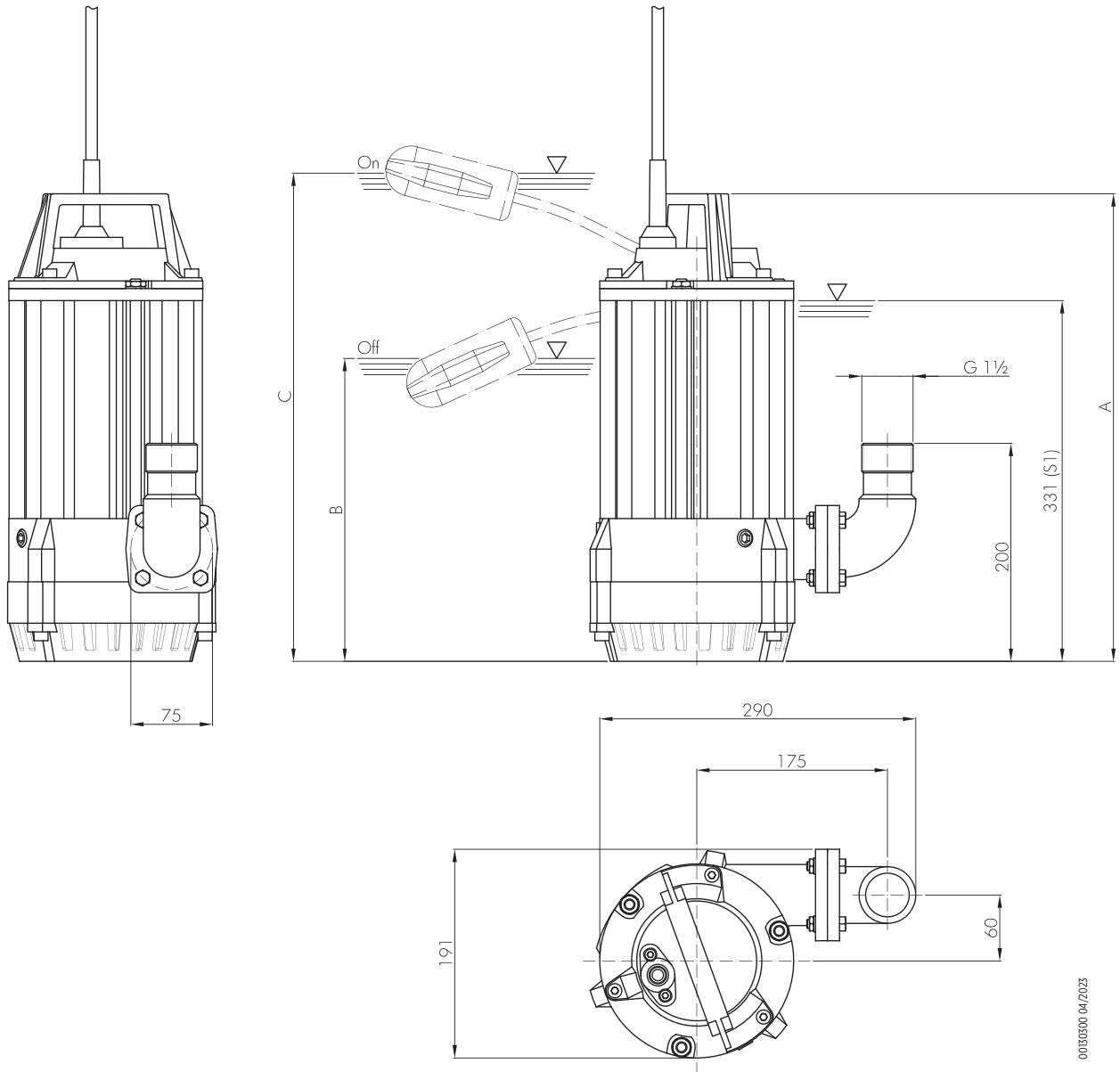

00183800 04/2023

Pump model	Dimensions [mm]		
	A	B	C
40FDP-52-1,4M-HH	429	-	-
40FDP-52-1,4M-G-HH	469	250	570
40FDP-52-1,8M-HH	429	-	-
40FDP-52-1,8T-HH	429	-	-
40FDP-52-1,8M-G-HH	469	250	570
40FDP-52-1,8T-G-HH	469	250	570

Pump model	Packaging	
	Dimensions [mm]	Weight [kg]
40FDP-52-1,4M-HH	290x245x585	23
40FDP-52-1,4M-G-HH	290x245x585	25
40FDP-52-1,8M-HH	290x245x585	26
40FDP-52-1,8T-HH	255x205x560	22,7
40FDP-52-1,8M-G-HH	290x245x585	28
40FDP-52-1,8T-G-HH	290x245x585	25

TECHNICAL DATA

Pump model	Motor absorbed power P ₁	Rated power P ₂		Voltage	Rated current	Phase	Power cable		Float switch	Running capacitor	Delivery port	Weight [kg]
	[kW]	[kW]	[HP]	[V]	[A]		length [m]	Type		[μf]		
40FDP-52-1,4M-HH	2,2	1,4	1,9	230	12	1 ~	10	4G2,5	-	25	G1½	22
40FDP-52-1,4M-G-HH	2,2	1,4	1,9	230	12	1 ~	10	4G2,5	•	25	G1½	24
40FDP-52-1,8M-HH	2,7	1,8	2,4	230	14	1 ~	10	4G2,5	-	30	G1½	25
40FDP-52-1,8T-HH	2,4	1,8	2,4	400	4,6	3 ~	10	4G1,5	-	-	G1½	22
40FDP-52-1,8M-G-HH	2,7	1,8	2,4	230	14	1 ~	10	4G2,5	•	30	G1½	27
40FDP-52-1,8T-G-HH	2,4	1,8	2,4	400	4,6	3 ~	10	4G1,5	•	-	G1½	24

"-" = not available

• = available

HYDRAULIC PERFORMANCE AT 50 HZ

Pump model	Phase	Q = Delivery							
		l/sec 0	1	2	3	4	5	6	7
		m ³ /h 0	3,6	7,2	10,8	14,4	18	21,6	25,2
		US gpm 0	15,8	31,7	47,5	63,4	79,2	92,1	110,9
H = Total meters head of water column [m]									
40FDP-52-1,4 HH	1 ~	31	27	23	19	14,5	10	5,2	
40FDP-52-1,8 HH	1 ~	32	29,5	26	22	18	13	7,8	2
40FDP-52-1,8 HH	3 ~	32	29,5	26	22	18	13	7,8	2

PERFORMANCE CURVES AT 50 HZ

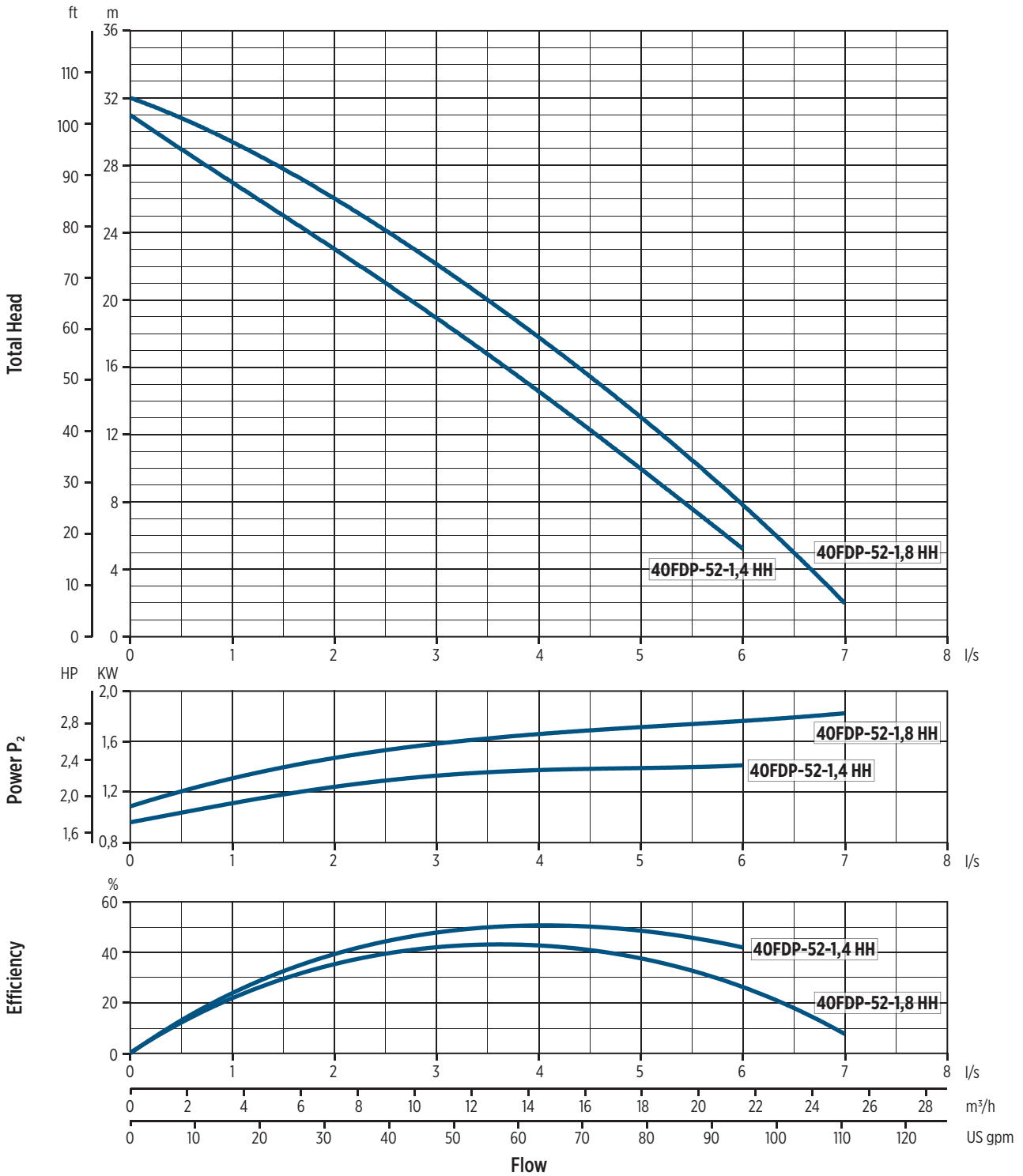

002010-04/2023

70/80FDP SERIES 50 HZ

FEATURES & BENEFITS

APPLICATIONS



Drainage and dewatering



Rainwater Recovery



Construction site drainage and dewatering



Mining, Quarrying drainage and dewatering



Emergency flood water drainage



MARKETS



COMMERCIAL

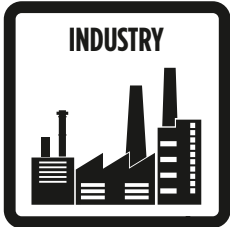

INDUSTRY



CONSTRUCTION



MINING

SUBMERSIBLE PUMPS FOR CLEAR AND TURBID WATER DRAINAGE

Submersible electric pumps suitable for draining clear and turbid water. Suitable for use on construction sites and for pumping liquids, including abrasive ones. Due to their handling they can be easily transported.

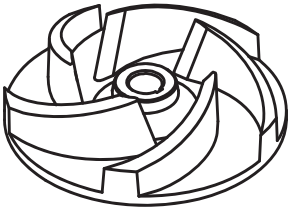

0032625 04/2023

OPEN IMPELLER

GENERAL FEATURES

		Materials/Constr.design
Open impeller		Martensitic stainless steel
External casing		Aluminium alloy
Pump body		Aluminium alloy
Cover		Aluminium alloy
Filter		Stainless steel AISI304
Wear plate		Graphite/Alumina
Mechanical seal		Silicon carbide (SiC/SiC)
Motor shaft		Stainless steel AISI420
Power cable	Type	10 m H07RN-F type
	Single-phase 70FDP-52-2,2M	4G2,5mm ² , capacitor box and SCHUKO plug (CEE 7/VII)
	Three-phase 80FDP-52-4,1T	4G2,5mm ²
	Three-phase	4G1,5mm ²
		Motor
Constr.design		asynchronous squirrel cage-type in dry chamber
Type		2 poles; 50 Hz
Insulation class		F
Protection degree		IP68
Voltage	Single-phase	230 V ±6%
	Three-phase	230V ±10%, 400V ±10%
		Limits of use
Maximum liquid temperature		+ 40°C
pH of pumped liquid		5 - 8
Liquid density		1,1 Kg/dm ³
Maximum immersion depth:		5 m
Min. immersion depth for continuous service		457 mm
Free passage		6 mm
Max. number of starting/hour		20
		Construction options

- 60 Hz version
- Different voltages
- With coating in composite material for wear protection (possible variations of the hydraulic performance)

DIMENSIONAL DRAWINGS

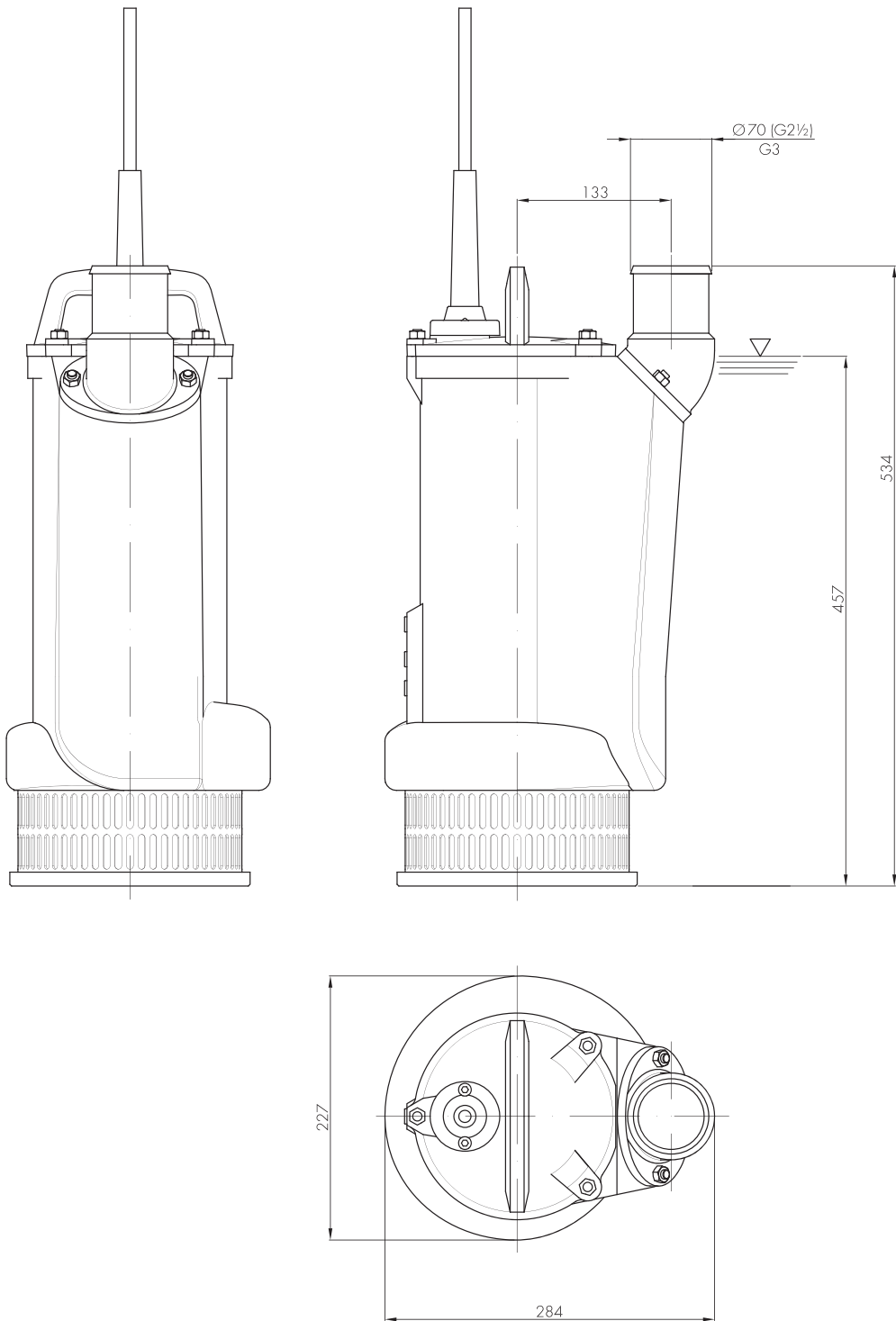

0013030104/2023

Packaging		
Pump model	Dimensions [mm]	Weight [kg]
70FDP-52-2,2	300x260x585	34
70FDP-52-3,5	290x245x585	32
80FDP-52-4,1	300x260x585	36

TECHNICAL DATA

Pump model	Motor absorbed power P ₁	Rated power P ₂		Voltage	Rated current	Phase	Power cable		Float switch	Running capacitor	Delivery port	Weight [kg]
	[kW]	[kW]	[HP]	[V]	[A]		length [m]	Type		[μf]		
70FDP-52-2,2M	3	2,2	3	230	14	1 ~	10	4G2,5	-	50	Ø70	33
70FDP-52-2,2T	3	2,2	3	400	5,2	3 ~	10	4G1,5	-	-	Ø70	30
70FDP-52-3,5T	4,7	3,5	4,7	400	8	3 ~	10	4G1,5	-	-	Ø70	31
80FDP-52-4,1T	6,2	4,1	5,5	400	9,9	3 ~	10	4G2,5	-	-	G3	35

"-" = not available

• = available

HYDRAULIC PERFORMANCE AT 50 HZ

Pump model	Phase	Q = Delivery										
		l/sec 0	2	4	6	8	10	12	15	20	25	28
		m ³ /h 0	7,2	14,4	21,6	28,8	36	43,2	54	72	90	100,8
		US gpm 0	31,7	63,4	92,1	126,8	158,5	190,2	237,7	317	396,2	443,8
		H = Total meters head of water column [m]										
70FDP-52-2,2	1 ~	16	15	14	12,8	11,3	9,6	8	5			
70FDP-52-2,2	3 ~	16	15	14	12,8	11,3	9,6	8	5			
70FDP-52-3,5	3 ~	21	20,5	19,5	18,5	17	15,5	13,5	9,5	4		
80FDP-52-4,1	3 ~	23,3	22,9	22,5	21	20,5	18,5	17,5	15,8	11,5	6,5	3,8

PERFORMANCE CURVES AT 50 HZ

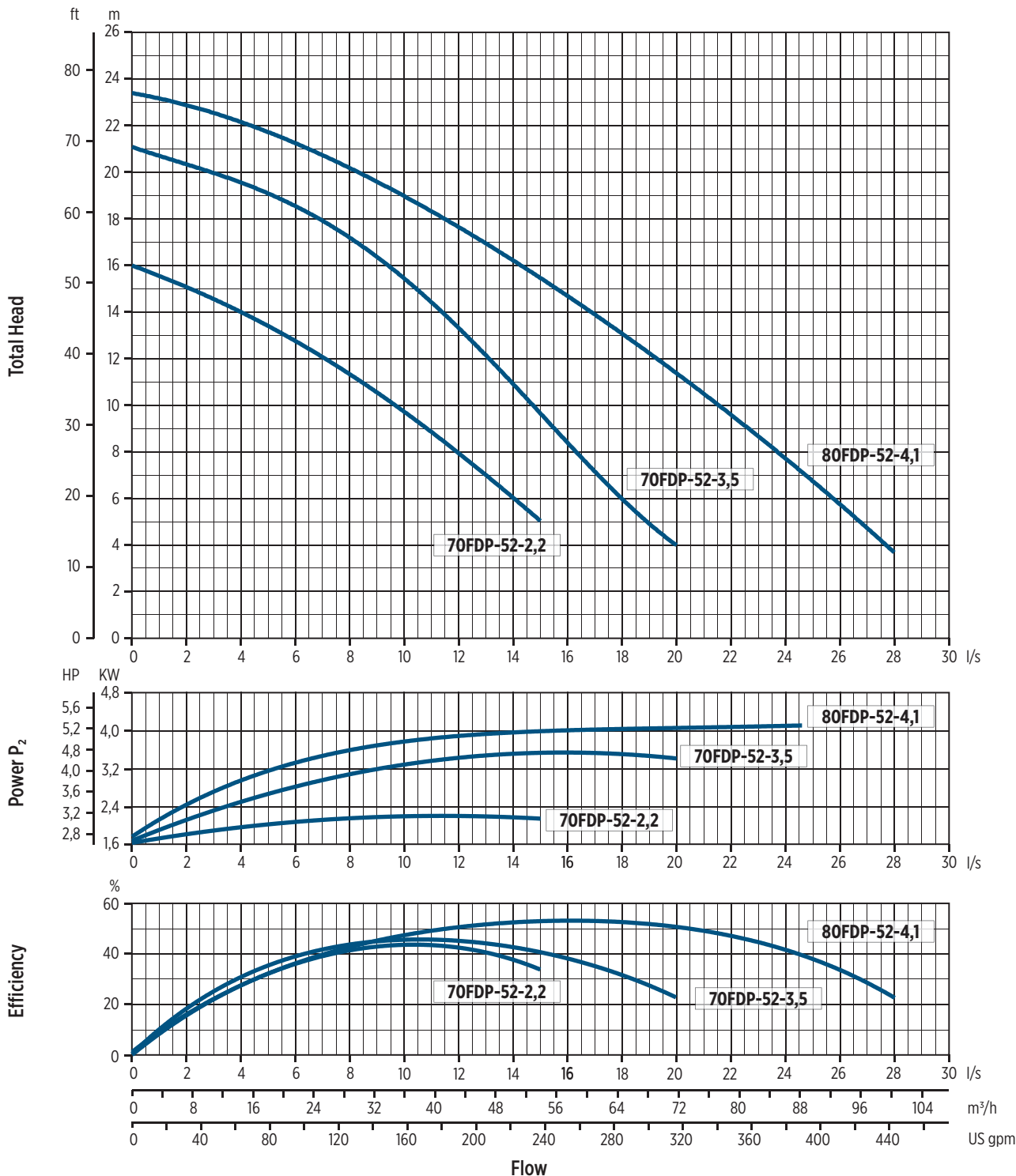

002011/04/2023

100FDP SERIES 50 HZ

FEATURES & BENEFITS

APPLICATIONS



Drainage and dewatering



Rainwater Recovery



Construction site drainage and dewatering



Mining, Quarrying drainage and dewatering



Emergency flood water drainage



MARKETS

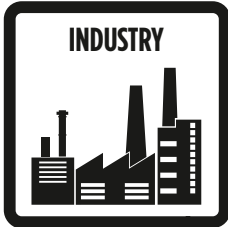

SUBMERSIBLE PUMPS FOR CLEAR AND TURBID WATER DRAINAGE

Submersible electric pumps suitable for draining clear and turbid water. Suitable for use on construction sites and for pumping liquids, including abrasive ones.

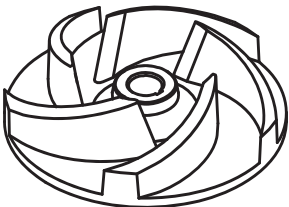

003205 04/2023

OPEN IMPELLER

GENERAL FEATURES

Materials/Constr.design		
Open impeller	High chrome cast iron	
External casing	Stainless steel AISI304	
Pump body	Cast iron EN GJL 200 with rubber coating	
Cover	Cast iron EN GJL250	
Filter	Stainless steel AISI304	
Wear plate	Cast iron EN GJL 250 with rubber coating	
Mechanical seal	motor side	Graphite/Alumina
	pump side	Silicon carbide (SiC/SiC)
Motor shaft	Stainless steel AISI431	
Power cable	Type	20 m SIRN8-F type
	Three-phase 100FDP-52-5,5T, 100FDP-52-6,5T	4G2,5+3x1mm ²
	Three-phase 100FDP-52-8,1T	4G4+3x1mm ²
Motor		
Constr.design	asynchronous squirrel cage-type in dry chamber	
Type	2 poles; 50 Hz	
Insulation class	F	
Protection degree	IP68	
Voltage	Three-phase	400V ±10%
Limits of use		
Maximum liquid temperature	+ 40°C	
pH of pumped liquid	6 - 10	
Liquid density	1,1 Kg/dm ³	
Maximum immersion depth:	15 m	
Min. immersion depth for continuous service	150 mm	
Free passage	10 mm	
Max. number of starting/hour	15	
Construction options		

- 60 Hz version
- Different voltages
- Inner control of the thermal probes in the winding, control sequence and lack of phase (on request)

DIMENSIONAL DRAWINGS

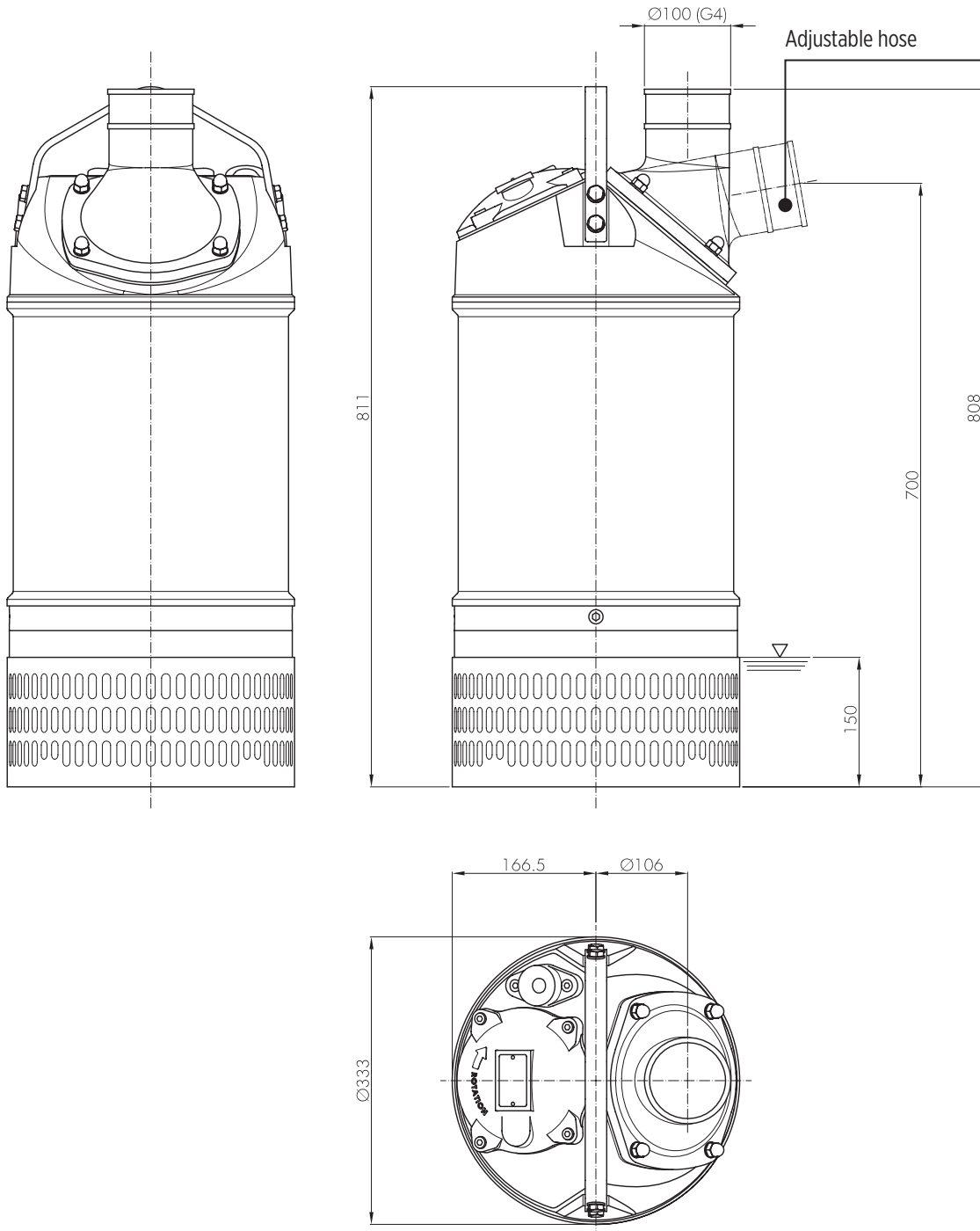

00130302_04/2023

Packaging		
Pump model	Dimensions [mm]	Weight [kg]
100FDP-52-5,5T-LH	475x370x985	128
100FDP-52-5,5T-HH	475x370x985	128
100FDP-52-6,5T-LH	475x370x985	133
100FDP-52-6,5T-HH	475x370x985	133
100FDP-52-8,1T-LH	475x370x985	138
100FDP-52-8,1T-HH	475x370x985	138

TECHNICAL DATA

Pump model	Motor absorbed power P ₁	Rated power P ₂		Voltage	Rated current	Phase	Power cable		Float switch	Running capacitor	Delivery port	Weight [kg]
	[kW]	[kW]	[HP]	[V]	[A]		length [m]	Type		[µf]		
100FDP-52-5,5T-LH	6	5,5	7,5	400	11	3 -	20	4G2,5+3x1	-	-	Ø100	125
100FDP-52-5,5T-HH	6	5,5	7,5	400	11	3 -	20	4G2,5+3x1	-	-	Ø100	125
100FDP-52-6,5T-LH	7,2	6,5	8,8	400	13	3 -	20	4G2,5+3x1	-	-	Ø100	130
100FDP-52-6,5T-HH	7,2	6,5	8,8	400	13	3 -	20	4G2,5+3x1	-	-	Ø100	130
100FDP-52-8,1T-LH	9	8,1	11	400	16	3 -	20	4G4+3x1	-	-	Ø100	135
100FDP-52-8,1T-HH	9	8,1	11	400	15	3 -	20	4G4+3x1	-	-	Ø100	135

"-" = not available

• = available

HYDRAULIC PERFORMANCE AT 50 HZ

Pump model	Phase	Q = Delivery											
		l/sec 0	2,5	5	10	15	20	25	30	35	40	45	50
		m ³ /h 0	9	18	36	54	72	90	100,8	108	144	162	180
		US gpm 0	39,6	79,2	158,5	237,7	317	396,2	443,8	475,5	634	713,3	792,5
		H = Total meters head of water column [m]											
100FDP-52-5,5 LH	3 -	18,9		17,5	15,7	13,4	11,3	9,1	7	5,1	2,5		
100FDP-52-5,5 HH	3 -	30	27,9	26	20,8	14,6	6,3						
100FDP-52-6,5 LH	3 -	22,4	0	21,4	20	17,6	15,1	12,7	10,9	8,8	6,6	3	
100FDP-52-6,5 HH	3 -	35,3	32,3	29,5	23,2	16,7	8,3						
100FDP-52-8,1 LH	3 -	25,9		24,6	22,9	20,7	18,3	15,9	14,1	12,1	9,7	6,8	3
100FDP-52-8,1 HH	3 -	45	40,7	36,6	28,8	20,2	10,1						

PERFORMANCE CURVES AT 50 HZ

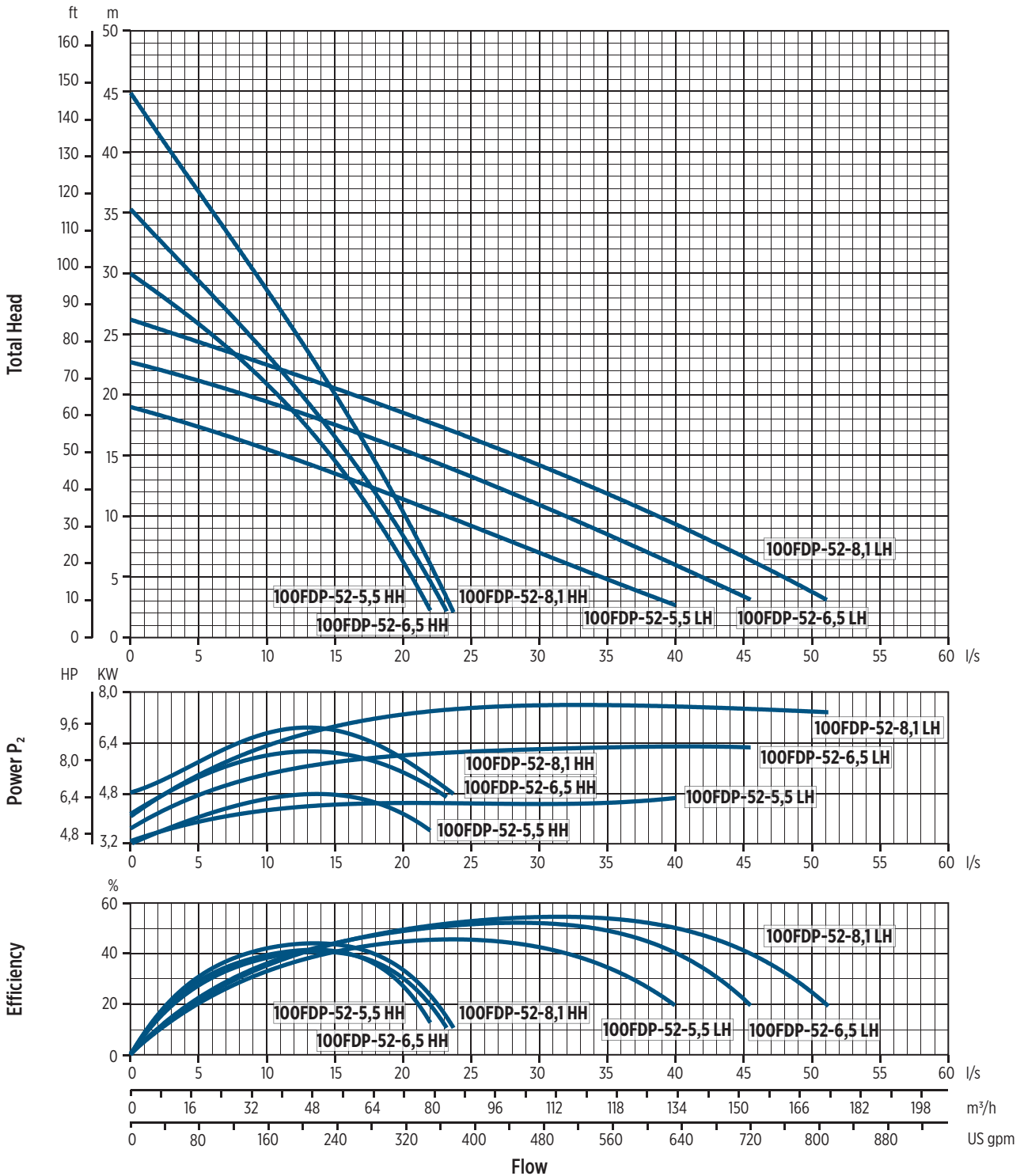

002012_04/2023

The hydraulic characteristics are guaranteed, according to ISO standard 9906:2012, grade 3B

100/150 FDP-LH/HH SERIES 50 HZ

FEATURES & BENEFITS

APPLICATIONS



Drainage and dewatering



Rainwater Recovery



Construction site drainage and dewatering



Mining, Quarrying drainage and dewatering



Emergency flood water drainage



MARKETS



COMMERCIAL

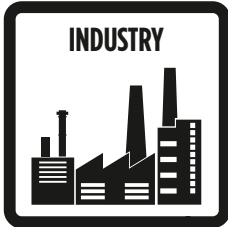

INDUSTRY



CONSTRUCTION



MINING

SUBMERSIBLE PUMPS FOR CLEAR AND TURBID WATER DRAINAGE

Submersible electric pumps suitable for draining clear and turbid water. Suitable for use on construction sites and for pumping liquids, including abrasive ones.

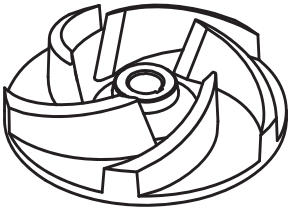

0032625 04/2023

OPEN IMPELLER

GENERAL FEATURES

Materials/Constr.design	
Open impeller	High chrome cast iron
External casing	Stainless steel AISI304
Pump body	Cast iron EN GJL 200 with rubber coating
Cover	Cast iron EN GJL250
Filter	Stainless steel AISI304
Wear plate	Cast iron EN GJL 250 with rubber coating
Mechanical seal	motor side
	pump side
Motor shaft	Stainless steel AISI431
Power cable	20 m 7G4+2x1,5mm ² , 07RN-F type
Motor	
Constr.design	asynchronous squirrel cage-type in dry chamber
Type	2 poles; 50 Hz
Insulation class	F
Protection degree	IP68
Voltage	Three-phase 400V ±10%
Limits of use	
Maximum liquid temperature	+ 40°C
pH of pumped liquid	6 - 10
Liquid density	1,1 Kg/dm ³
Maximum immersion depth:	15 m
Min. immersion depth for continuous service	200 mm
Free passage	6 mm
Max. number of starting/hour	10
Construction options	

- 60 Hz version
- Different voltages
- Inner control of the thermal probes in the winding, control sequence and lack of phase (on request)

DIMENSIONAL DRAWINGS

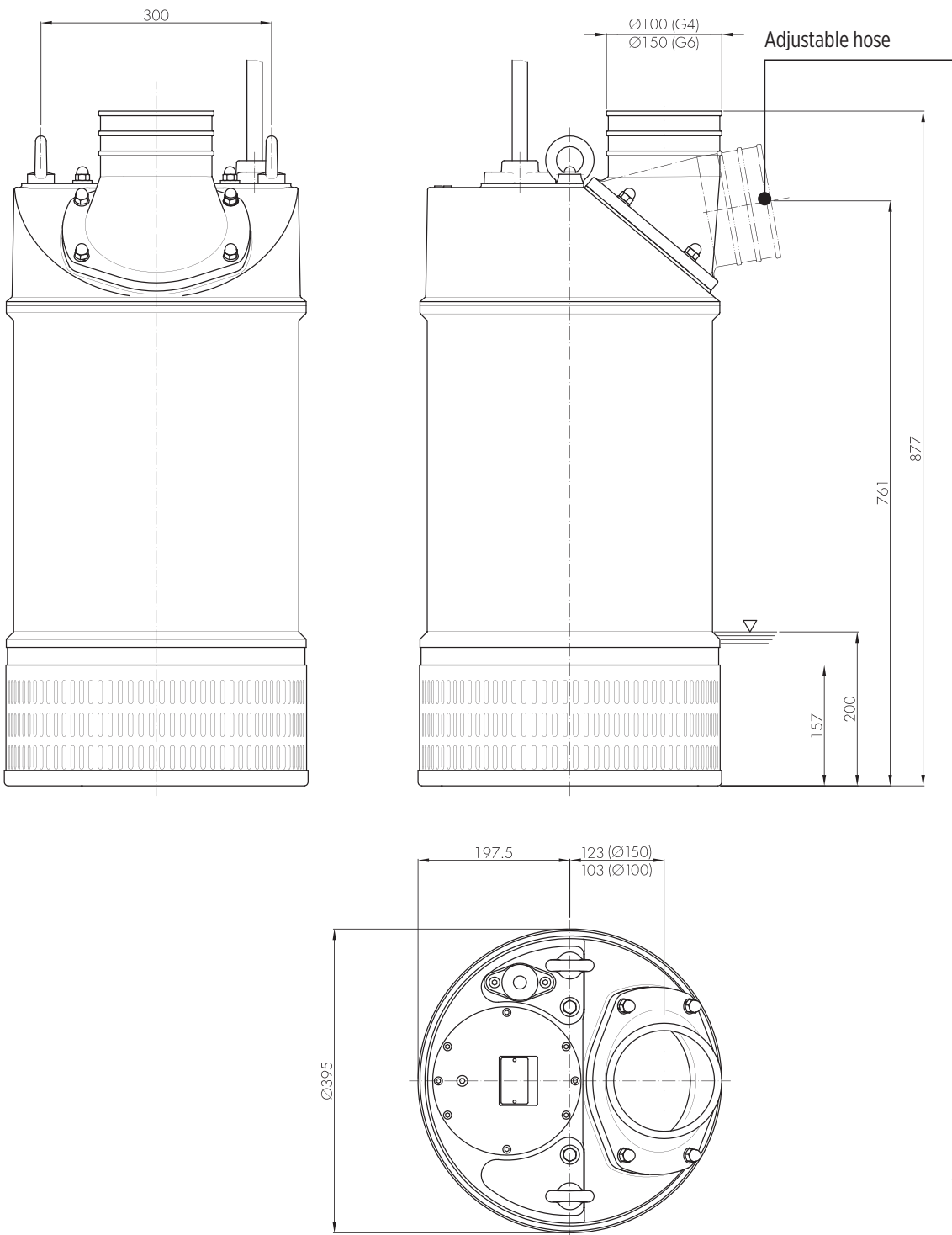

00130303 04/2023

Packaging		
Pump model	Dimensions [mm]	Weight [kg]
150FDP-52-11T-LH	620x420x1030	196
100FDP-52-11T-HH	620x420x1030	196
150FDP-52-15T-LH	620x420x1030	208
100FDP-52-15T-HH	620x420x1030	208

TECHNICAL DATA

Pump model	Motor absorbed power P ₁	Rated power P ₂		Voltage	Rated current	Phase	Power cable		Float switch	Running capacitor	Delivery port	Weight [kg]
	[kW]	[kW]	[HP]	[V]	[A]		length [m]	Type		[μf]		
150FDP-52-11T-LH	13	11	14,9	400	22	3 -	20	7G4+2x1,5	-	-	Ø150	192
100FDP-52-11T-HH	13	11	14,9	400	22	3 -	20	7G4+2x1,5	-	-	Ø100	192
150FDP-52-15T-LH	17	15	20,4	400	28	3 -	20	7G4+2x1,5	-	-	Ø150	204
100FDP-52-15T-HH	17	15	20,4	400	28	3 -	20	7G4+2x1,5	-	-	Ø100	204

"-" = not available

• = available

HYDRAULIC PERFORMANCE AT 50 HZ

Pump model	Phase	Q = Delivery														
		l/sec 0	5	10	15	20	25	30	35	40	45	50	55	60	65	70
		m ³ /h 0	18	36	54	72	90	100,8	108	144	162	180	198	216	234	252
		US gpm 0	79,2	158,5	237,7	317	396,2	443,8	475,5	634	713,3	792,5	871,8	951	1.030,3	1.109,5
		H = Total meters head of water column [m]														
150FDP-52-11 LH	3 -	30	28,3	26,8	24,8	22,8	21	19,3	17,2	15,3	13	10,7	6,7	3		
100FDP-52-11 HH	3 -	60	52,8	44,9	35,3	24	10									
150FDP-52-15 LH	3 -	32	30,6	29,3	27,8	26,4	24,3	22,3	20,3	18,5	16,6	14,8	12,4	10,1	6	2
100FDP-52-15 HH	3 -	62	54,6	48,4	42	35,1	25,8	16,4	2,3							

PERFORMANCE CURVES AT 50 HZ

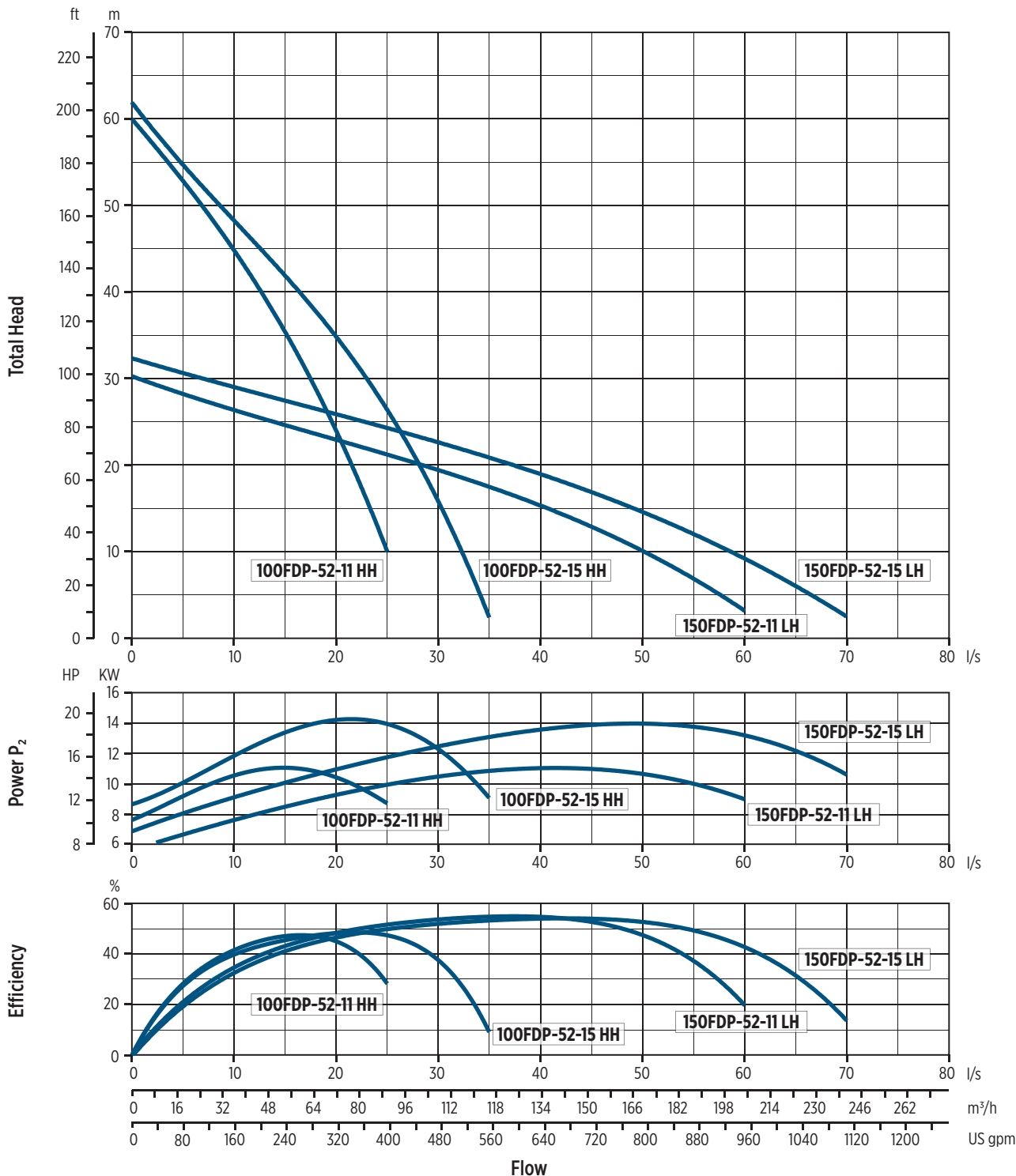

002013.04/2023

150FDP SERIES 50 HZ

FEATURES & BENEFITS

APPLICATIONS



Drainage and dewatering



Rainwater Recovery



Construction site drainage and dewatering



Mining, Quarrying drainage and dewatering



Emergency flood water drainage



MARKETS



COMMERCIAL

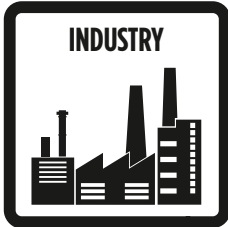

INDUSTRY



CONSTRUCTION



MINING

SUBMERSIBLE PUMPS FOR CLEAR AND TURBID WATER DRAINAGE

Submersible electric pumps suitable for draining clear and turbid water. Suitable for use on construction sites and for pumping liquids, including abrasive ones.

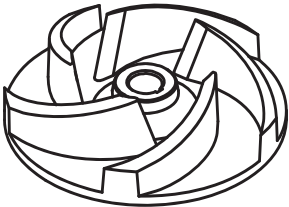

0030305 04/2023

OPEN IMPELLER

GENERAL FEATURES

Materials/Constr.design		
Open impeller	Stainless steel AISI304	
External casing	Aluminium alloy	
Pump body	Aluminium alloy with rubber coating	
Cover	Aluminium alloy	
Filter	Aluminium alloy	
Wear plate	Stainless steel AISI304 with rubber coating	
Mechanical seal	motor side	Graphite/Alumina
	pump side	Silicon carbide (SiC/SiC)
Motor shaft	Stainless steel AISI431	
Power cable	20 m 7G4+2x1,5mm ² , 07RN-F type	
Motor		
Constr.design	asynchronous squirrel cage-type in dry chamber	
Type	2 poles; 50 Hz	
Insulation class	F	
Protection degree	IP68	
Voltage	Three-phase 400V ±10%	
Limits of use		
Maximum liquid temperature	+ 40°C	
pH of pumped liquid	5 - 8	
Liquid density	1,1 Kg/dm ³	
Maximum immersion depth:	15 m	
Min. immersion depth for continuous service	350 mm	
Free passage	7 mm	
Max. number of starting/hour	10	
Construction options		

- 60 Hz version
- Different voltages

DIMENSIONAL DRAWINGS

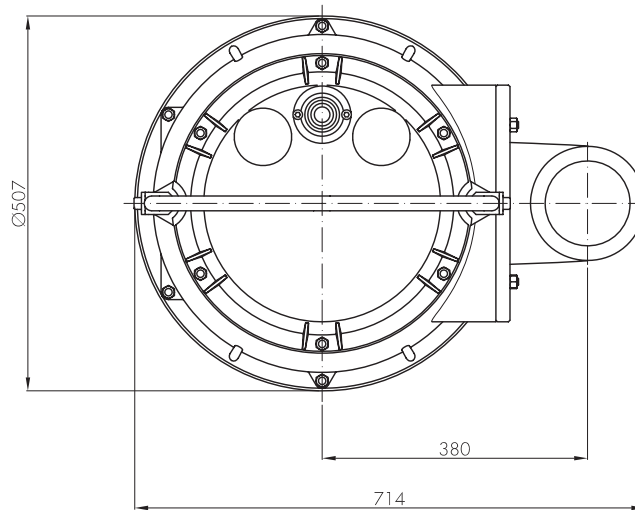
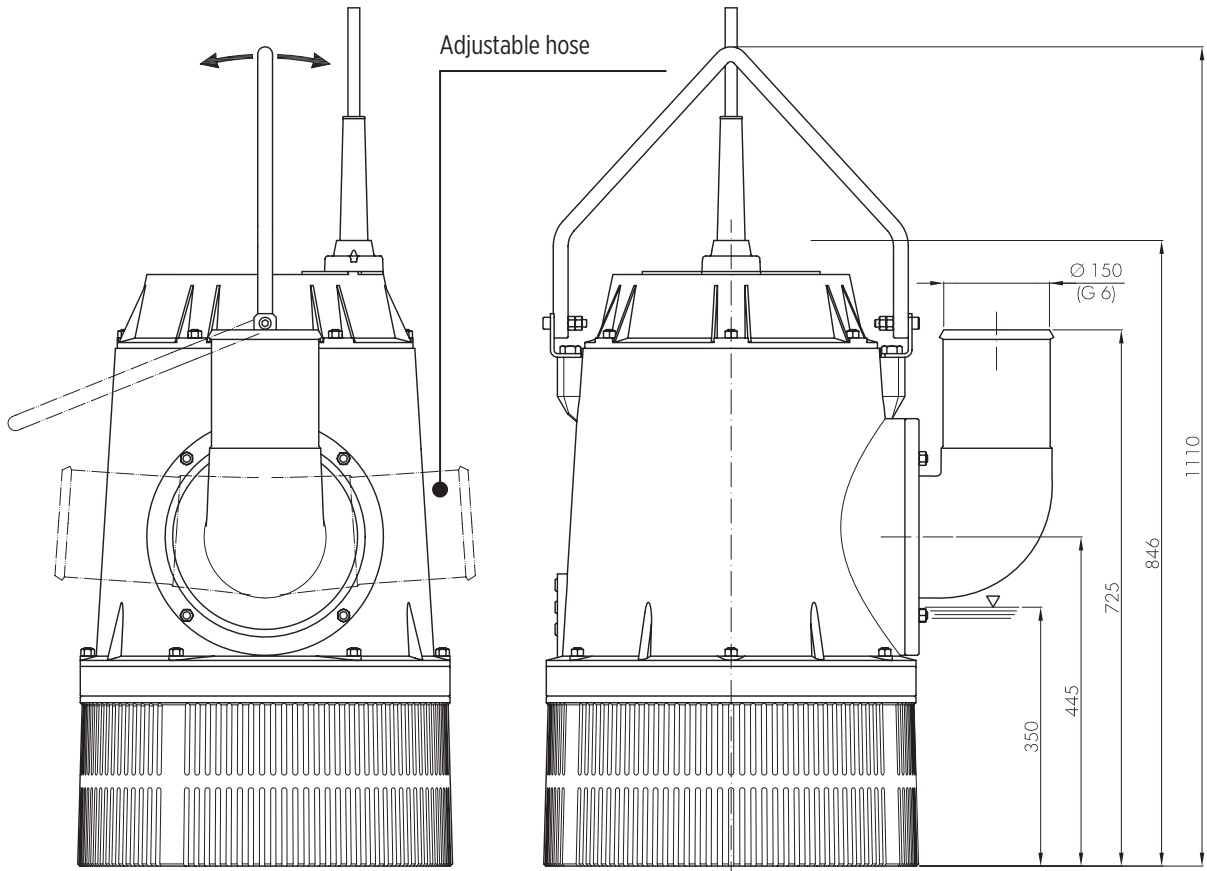

00130304-04/2023

Packaging		
Pump model	Dimensions [mm]	Weight [kg]
150FDP-52-22T	650x800x1200	233

TECHNICAL DATA

Pump model	Motor absorbed power P ₁	Rated power P ₂		Voltage	Rated current	Phase	Power cable		Float switch	Running capacitor	Delivery port	Weight [kg]
	[kW]	[kW]	[HP]	[V]	[A]		length [m]	Type		[μf]		
150FDP-52-22T	28	22	30	400	46	3 -	20	7G4+2x1,5	-	-	Ø150	183

“-” = not available
 • = available

HYDRAULIC PERFORMANCE AT 50 HZ

Pump model	Phase	Q = Delivery											
		l/sec 0	20	25	30	35	40	45	50	60	70	80	90
		m ³ /h 0	72	90	100,8	108	144	162	180	216	252	288	324
		US gpm 0	317	396,2	443,8	475,5	634	713,3	792,5	951	1.109,5	1.268	1.426,5
		H = Total meters head of water column [m]											
150FDP-52-22	3 -	35	32	31	29	28	26	24	22	18,5	15	11	5

PERFORMANCE CURVES AT 50 HZ

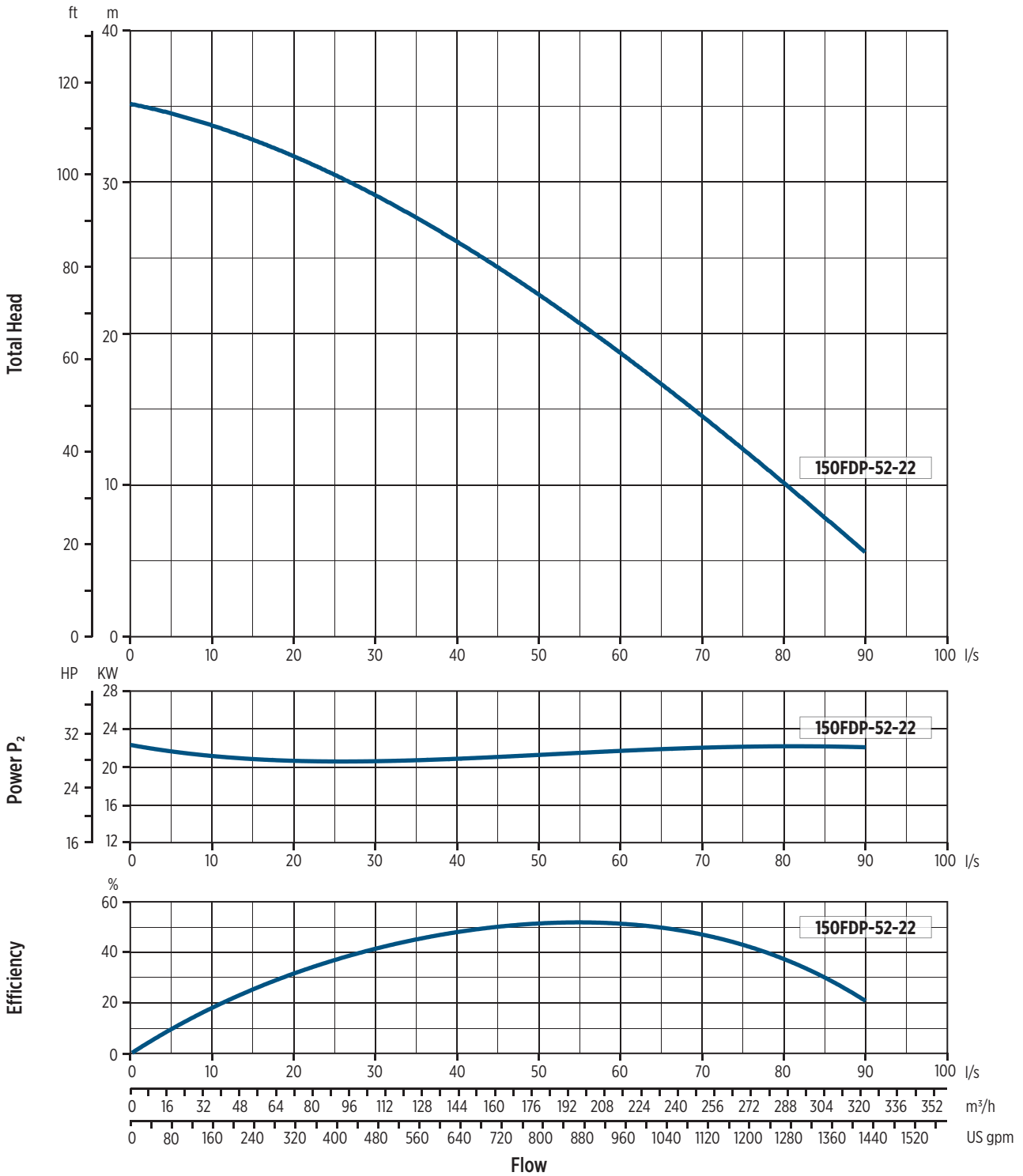

002014-04/2023

CATALOG REVISION CHANGE NOTICE

Rev. No.	Changes	Page
01	150FDP graphic scale correction	48
01	40FDR and 50FDR General Features motor voltage single-phase correction	6, 12



Geoquip Water Solutions Ltd. Unit
7, Sovereign Centre Farthing Road
Ipswich, Suffolk, IP1 5AP, UK Phone:
01473 462046
www.geoquipwatersolutions.com



Franklin Electric



franklinwater.eu

Franklin Electric Europa GmbH
Rudolf-Diesel-Str. 20 - 54516 Wittlich
GERMANY
Phone: +49 (0) 6571 - 105-0
Fax: +49 (0) 6571 - 105-510
Email: info@franklin-electric.de

Franklin Electric S.r.l.
Via Asolo, 7 - 36031 Dueville (Vicenza)
ITALY
Phone: +39 0444 361114
Fax: +39 0444 365247
Email: sales.it@fele.com



10000015089 EN REV.01_08-2023

Single member - Company subject to the control and coordination of Franklin Electric Co., Inc.
Franklin Electric reserves the right to amend specification without prior notice.